

# *Buffered Smart Switch*

## **Model 232BSS4**

Documentation Number: 232BSS4-2907

*This product designed and manufactured in Ottawa, Illinois USA  
of domestic and imported parts by*



707 Dayton Road -- P.O. Box 1040 -- Ottawa, IL 61350 USA  
Phone (815) 433-5100 -- General Fax (815) 433-5105

**Phone** (815) 433-5100 -- **General Fax** (815) 433-5105

Website: [www.bb-elec.com](http://www.bb-elec.com)

**Sales** e-mail: [orders@bb-elec.com](mailto:orders@bb-elec.com) -- **Fax** (815) 433-5109

**Technical Support** e-mail: [support@bb.elec.com](mailto:support@bb.elec.com) -- **Fax** (815) 433-5104

### European Headquarters

B&B Electronics

Westlink Commercial Park -- Oranmore, Co. Galway, Ireland

**Phone** +353 91-792444 -- **Fax** +353 91-792445

Website: [www.bb-europe.com](http://www.bb-europe.com)

**Sales** e-mail: [sales@bb-europe.com](mailto:sales@bb-europe.com)

**Technical Support** e-mail: [support@bb-europe.com](mailto:support@bb-europe.com)

B&B Electronics Mfg. Co. Inc. -- July 2007

---

Manual Documentation Number: 232BSS4-2907

B&B Electronics Mfg Co Inc - 707 Dayton Rd - PO Box 1040 - Ottawa IL 61350 - Ph 815-433-5100 - Fax 815-433-5104 - [www.bb-elec.com](http://www.bb-elec.com)  
B&B Electronics - Westlink Commercial Park - Oranmore, Galway, Ireland - Ph +353 91-792444 - Fax +353 91-792445 - [www.bb-europe.com](http://www.bb-europe.com)

This document contains information that is proprietary and confidential to B&B Electronics Mfg. Co. Inc. The methods described herein are for the exclusive use of B&B Electronics authorized personnel. Any unauthorized use or dissemination of the information contained in the document is strictly forbidden.

---

B&B Electronics Mfg Co Inc – 707 Dayton Rd - PO Box 1040 - Ottawa IL 61350 - Ph 815-433-5100 - Fax 815-433-5104 – [www.bb-elec.com](http://www.bb-elec.com)  
B&B Electronics – Westlink Commercial Park – Oranmore, Galway, Ireland – Ph +353 91-792444 – Fax +353 91-792445 – [www.bb-europe.com](http://www.bb-europe.com)

# Table of Contents

<b>CHAPTER 1 – INTRODUCTION.....</b>	<b>1</b>
SPECIFICATIONS .....	2
DEFAULT PARAMETERS .....	2
CHECKLIST.....	3
<b>CHAPTER 2: OPERATION.....</b>	<b>5</b>
SYMBOLS AND CONVENTIONS.....	5
LED INDICATORS.....	5
PORT CONFIGURATIONS .....	6
SMART SWITCH ONLY MODE.....	7
AUTO SELECT/SMART SWITCH MODE.....	14
USING THE 232BSS4 AS A BUFFERED SPLITTER/COMBINER .....	16
BACK TO BACK OPERATION (MUX/DEMUX) .....	17
CASCADING MULTIPLE SWITCHES .....	18
<b>CHAPTER 3: PORT CONNECTIONS .....</b>	<b>21</b>
DTE/DCE EXPLANATION .....	21
<b>CHAPTER 4: SETUP SOFTWARE.....</b>	<b>23</b>
INTRODUCTION .....	23
CONNECTION.....	23
SOFTWARE INSTALLATION .....	24
SOFTWARE UNINSTALL .....	24
SETUP TUTORIAL .....	25
<b>APPENDIX A: ASCII CHARACTER CODES.....</b>	<b>1</b>
<b>APPENDIX B: CABLE CHARTS.....</b>	<b>1</b>
CHART B.1. DTE (PC) DB25 CONNECTOR TO MASTER PORT.....	1
CHART B.2. DTE (PC) DB9 CONNECTOR TO MASTER PORT.....	1
CHART B.3. DCE (MODEM) DB25 CONNECTOR TO MASTER PORT .....	3
CHART B.4. DCE (MODEM) DB9 CONNECTOR TO MASTER PORT .....	3
CHART B.5. PORTS A - D (DTE) TO DTE (PC) DB25 CONNECTOR.....	4
CHART B.6. PORTS A - D (DTE) TO DTE (PC) DB9 CONNECTOR.....	4
CHART B.7. PORTS A - D (DTE) TO DCE (MODEM) DB25 CONNECTOR ..	4
CHART B.8. PORTS A - D (DTE) TO DCE (MODEM) DB9 CONNECTOR ...	5
<b>APPENDIX C: BLOCK DIAGRAM.....</b>	<b>1</b>
<b>APPENDIX D: DECLARATION OF CONFORMITY.....</b>	<b>1</b>



## Chapter 1 – Introduction

The 232BSS4 provides communications to four devices from one serial port. Each port uses a dedicated UART and includes an 8K byte transmit buffer and an 8K byte receive buffer (16K bytes total). Each port can be independently configured for data rate, data format, and protocol. The Master port can send and receive data from one of the Slave ports while the other Slave ports continue to buffer data. The Master device can also broadcast the same message to two or more Slave ports at once.

The 232BSS4 can be configured to send data automatically to the Master port from each of the Slave ports when data is present with an optional preamble identifying the port. It can also provide two-way communications between the Master port and one Slave port at a time. Switching and control is done through user-defined three or four character command strings. All control sequences are removed from the data stream, making the switch transparent to the Slave devices. The PC setup software provided walks the user through all possible parameters.

Switches can be cascaded to expand the 232BSS4 to more than four ports. Two units can also be used back-to-back to provide automatic connection between devices over a single data channel. LEDs on the 232BSS4 indicate when the unit is powered up and which port is selected to send data to the Master port.



## **Specifications**

<b>Model:</b>	232BSS4
<b>Interface:</b>	RS-232 asynchronous
<b>Data Format:</b>	7 or 8 data bits, even, odd, or no parity (Master does not support 7 data bits with no parity) 1 stop bit (fixed)
<b>Data Rate:</b>	1200 to 115.2 kbps
<b>Flow Control:</b>	Hardware(RTS/CTS) or None
<b>Power Requirements:</b>	+10 to +15 VDC @ 60 mA max.
<b>Power Connector:</b>	2.5 mm phone jack (+ tip)
<b>Recommended Supply:</b>	B&B Model 232PS (Sold separately)
<b>Operating Temperature:</b>	0° to 70° C
<b>Data Connectors:</b>	Master DB25 female (DCE) Slaves DB9 male x 4 (DTE)
<b>Dimensions:</b>	7.5 x 4.6 x 1.2 in. (19.0 x 11.7 x 3.0 cm)
<b>Setup Software:</b>	PC compatible, Windows 95/98/NT/2000/XP/Vista
<b>Supplied Accessories:</b>	CDROM with Setup Program Instruction Manual

## **Default Parameters**

When shipped, the 232BSS4 comes set up for the following parameters:

- Auto Select mode OFF
- DTR NOT required to accept commands
- THREE character command
- Char1 = ESC (Decimal 27)
- Char2 = STX (Decimal 2)
- Char3 = "0" (Not Used)
- Port Time = 1,000mS (not used)
- Inactivity Time = 500mS (not used)
- All ports 9600 Baud
- All ports 8 Data Bits
- All ports No Parity
- All ports No Hardware Handshake required
- Ports A-D No preamble
- Port A selected to Transmit & Receive on Power-up

Refer to the following sections of the manual for what each of these parameters means and how they can be changed.

## **Checklist**

Examine the shipping carton and contents for physical damage. If damage is found, file a claim with the shipper immediately.

The following equipment should be in the shipping carton:

1. RS-232 Buffered Smart Switch model 232BSS4
2. Instruction Manual
3. (2) 3.5" floppy disks

If any of the items above are not in the shipping carton contact the shipper immediately.





## Chapter 2: OPERATION

### ***Symbols and Conventions***

Throughout this chapter of the manual, the following symbols and conventions will be used to clarify what type of data we are addressing.

- Items enclosed in {brackets} will denote one byte.
- A character in “quotes” will normally denote a printable ASCII character. A byte described in ALL CAPS is the ASCII description of a non-printable character. The abbreviation dec will denote a decimal value. The lower case letter h will be used to show a Hex value.
- Items in *italics* are optional items only used in certain configurations. The instances when these items are required will be explained in the text.

### ***LED Indicators***

The 232BSS4 has five LED indicators. The first, labeled “+12 VDC POWER” indicates that power is applied to the switch. The other four, labeled “PORT A” to “PORT D” indicate which Slave port is currently selected to transmit to the Master.

In Smart Switch Only mode, the port LEDs indicate which port was selected through the Select Port command. In Auto Select mode, the port LEDs indicate which port is currently sending to the Master. No indication is provided to display which Slave port is currently receiving from the Master.

## **Port Configurations**

The 232BSS4 provides a dedicated UART to all five ports. This allows any port to be individually configured for baud rate, number of data bits, parity, and hardware (RTS/CTS) handshaking. Configuration of all the ports is done through the setup software.

### **Baud Rate:**

Each port is configurable for the following baud rates:

1200  
2400  
4800  
9600  
19.2K  
38.4K  
57.6K  
or 115.2 kbps

### **Data Bits:**

Each port can be configured for Seven or Eight data bits.

**Note:** If the Master and Slaves are set up differently, the port set for Seven data bits cannot transmit the eighth bit.

### **Parity:**

Each port can be configured for Even, Odd, or No parity. Because the Master port uses a slightly different UART, it is not capable of receiving only seven bits, thus seven data bits with no parity is not allowed on the Master port. All other configurations are possible.

### **Stop bits:**

Each port uses 1 stop bit. This value is currently fixed and can not be changed in the setup software.

### **Hardware(RTS/CTS) Handshaking:**

Each port can be configured to hold data until its input handshake line goes high. On the Master port, pin four (RTS) would have to be held high by the host device in order for the 232BSS4 to send data. On the Slaves, pin eight (CTS) needs to be held high by the Slave device for the 232BSS4 to send data. The connected devices can prevent data from being sent from the 232BSS4 by holding their corresponding handshake lines low.

## **Smart Switch Only Mode**

### **Description:**

Smart Switch Only mode is used when the host device connected to the Master port initiates all communications with the Slave devices. To use the 232BSS4 as a Smart Switch Only, Auto Select is left unchecked in the setup software.

In Smart Switch Only mode, the 232BSS4 is constantly looking for a command sequence by monitoring the data that is being received on the Master port from the host device. This command can tell the 232BSS4 to connect the Master port to a single Slave port, send data to one or more Slave ports at once, discontinue communications with all Slave ports, or ignore commands for a specific length of time.

All command characters are buffered until the full command sequence is received. If the 232BSS4 recognizes the data stream as a command sequence, the sequence is not passed through the switch.

### **Options:**

#### **Initial Connections:**

Upon power-up, the 232BSS4 can be initialized to allow the Master access to any of the Slave ports without any commands sent. The Master to Slave and Slave to Master initialization are each independently configurable through the setup software. The Master can also be set to broadcast to any or all of the Slave ports on power-up. If no ports are selected to be initialized on power-up, the 232BSS4 will wait for a switching command before allowing the Master access to any of the Slaves.

#### **3 or 4 Character Command:**

The 232BSS4 commands can be set to be either three or four characters long. The first two or three characters can be programmed to any value through the setup software. The third or fourth character is the actual command.

Thus the command sequence would look like:

{Char1}{Char2}{Char3}{Command Character}

Char1-3 would be defined by the user through the setup software.

Char3 would only be sent if the 232BSS4 was set up for a four character command.

## Command Summary:

### Three Character Command Format:

Char1	Char2	Command Char	<i>Control Char</i>
-------	-------	--------------	---------------------

*Control Char* is only needed for Tx Only, Clear Buffer, and Ignore Commands

### Four Character Command Format:

Char1	Char2	Char3	Command Char	<i>Control Char</i>
-------	-------	-------	--------------	---------------------

*Control Char* is only needed for Tx Only, Clear Buffer, and Ignore Commands

**Table 2.1 - 232BSS4 Command Summary**

Function	Command Char.	Control Char.	Comments
Select Port A Tx & Rx	"A"	None	Switching Command
Select Port B Tx & Rx	"B"	None	Switching Command
Select Port C Tx & Rx	"C"	None	Switching Command
Select Port D Tx & Rx	"D"	None	Switching Command
Deselect All Ports	EOT	None	Switching Command
Tx Only to Specific Ports	"S"	Dec 0 to 15	Use to Broadcast
Clear Buffer on Specific Ports	"X"	Dec 0 to 15	Clear the Receive Buffer
Ignore Commands	"T"	"0" to "9"	Sets Timer Value

Values in quotes "" are ASCII characters.  
Dec. is an abbreviation for decimal value.

### Command Explanation:

Where applicable, this section will provide an example of how to create the command strings in Visual Basic. Other programming languages may require a slightly different syntax, but the examples given should provide enough information to port to other languages. For our examples, we will use the default settings of the switch:

- 3 Character Command Sequence
- Character 1 set to ASCII ESC character (Decimal 27)
- Character 2 set to ASCII STX character (Decimal 2)

If you choose to use a four character command sequence, just add another character between the second programmable character and the command character in the command string.

Commands:

Select Port A to transmit and receive – “A”

Select Port B to transmit and receive – “B”

Select Port C to transmit and receive – “C”

Select Port D to transmit and receive – “D”

The Select Port commands turn on the selected port for both transmit and receive operations. Once the command is received by the switch, any data that had been buffered from the selected Slave device will be sent to the Master. Any data received on the Master port that is not a valid command sequence will be passed to the selected Slave port until another command is received.

For instance, to send and receive data from port B, send:

{Char1}{Char2}{Char3}”B”

**VB Example:**

SwitchB\$ = CHR\$(27) & CHR\$(2) & “B”

Turn Off all selected ports – ASCII EOT character (decimal 4)

The Turn Off command deselects all ports. No ports will transmit or receive to/from the Master port until another command is received by the Master port.

The full command sequence to disable all ports is:

{Char1}{Char2}{Char3}/EOT

**VB Example:**

OFF\$ = CHR\$(27) & CHR\$(2) & CHR\$(4)

Send Only to specific ports – “S” + one control byte specifying which ports to send.

The Send Only command will tell the 232BSS4 which Slave ports to send the following data to. This command can be used to broadcast data to more than one port at a time. The Slave port that is sending to the Master is not affected.

The lowest four bits of the control byte tell the 232BSS4 which ports should receive the following data. Bit 0 represents port A, Bit 1 represents port B, Bit 2 represents port C, and Bit 3 represents port D. In decimal, this represents a value of 1, 2, 4, and 8 respectively. To turn on more than one port, the decimal equivalents of each port are added together to give the final byte.

A summary of the control characters for each combination of ports is given in Table 2.2.

For instance, to broadcast to ports B & C, send:

{Char1}{Char2}{Char3}”S”{Decimal 6}  
(B = 2, C = 4, 2 + 4 = 6)

**VB Example:**

BroadcastBC\$ = CHR\$(27) & CHR\$(2) & “S” & CHR\$(6)

Clear Receive Buffer – “X” + one control byte specifying which ports’ buffers to clear.

The Clear Buffer command will tell the 232BSS4 which Slave ports’ receive buffers to purge. If the Master device is only interested in the most recent data from the Slaves, this command can be used to delete old data from one or more of the Slave port buffers before it is sent to the Master.

The lowest four bits of the control byte tell the 232BSS4 which ports’ buffers to purge. Bit 0 represents port A, Bit 1 represents port B, Bit 2 represents port C, and Bit 3 represents port D. In decimal, this represents a value of 1, 2, 4, and 8 respectively. To clear more than one buffer with a single command, the decimal equivalents of each port would be added together to give the final byte.

A summary of the control characters for each combination of ports is given in Table 2.2.

For instance, to clear the receive buffer on ports A & D, send:

{Char1}{Char2}{Char3}”S”{Decimal 9}  
(A = 1, D = 8, 1 + 8 = 9)

**VB Example:**

ClearAD\$ = CHR\$(27) & CHR\$(2) & “X” & CHR\$(9)

**Table 2.2: Send Only and Clear Buffer Control Characters**

Ports to Transmit or Clear Receive Buffer	Binary Value (x = Don't Care)	Decimal Value	ASCII Character
None	xxxx0000	0 or 64	"@"
A Only	xxxx0001	1 or 65	"A"
B Only	xxxx0010	2 or 66	"B"
A & B	xxxx0011	3 or 67	"C"
C Only	xxxx0100	4 or 68	"D"
A & C	xxxx0101	5 or 69	"E"
B & C	xxxx0110	6 or 70	"F"
A, B, & C	xxxx0111	7 or 71	"G"
D Only	xxxx1000	8 or 72	"H"
A & D	xxxx1001	9 or 73	"I"
B & D	xxxx1010	10 or 74	"J"
A, B, & D	xxxx1011	11 or 75	"K"
C & D	xxxx1100	12 or 76	"L"
A, C, & D	xxxx1101	13 or 77	"M"
B, C, & D	xxxx1110	14 or 78	"N"
A, B, C, & D	xxxx1111	15 or 79	"O"

**Note:** The 232BSS4 ignores the upper 4 bits of the control byte. If the Master device is incapable of sending characters outside the printable ASCII range, decimal 64 can be added to each of the control bytes and the switch will operate properly.

Ignore Commands – "T" + one control byte specifying the length of time to ignore commands.

The Ignore Commands command tells the 232BSS4 to ignore all commands from the Master device for a specific amount of time. This command is useful if the data coming from the Master device may contain switching commands. By switching to a port, then sending the Ignore Commands command, all data received on the Master port of the 232BSS4 will be passed directly to the selected Slave port without checking for a command sequence until the programmed time has elapsed. The control byte at the end of the command tells the 232BSS4 how long to ignore commands from the Master device. This byte is ASCII "0" – "9" (48 – 57 Decimal). Timer values for each Control byte are given in Table 2.3.

For instance, to ignore switching commands for 30 Seconds, send:  
{Char1}{Char2}{Char3}“T”“7”

**VB Example:**

Ignore30s\$ = CHR\$(27) & CHR\$(2) & “T” & “7”

**Table 2.3 - Timer Values**

Control Byte (ASCII)	Control Byte (Decimal)	Timer Setting
“0”	48	Timer disabled
“1”	49	10ms
“2”	50	25ms
“3”	51	100ms
“4”	52	500ms
“5”	53	1 s
“6”	54	5 s
“7”	55	30 s
“8”	56	1 min.
“9”	57	5 min.

**Binary file transfer:**

Two methods are provided in the 232BSS4 to prevent inadvertent switching during a transfer of raw data bytes from the Master device to one or more Slaves. Because the user doesn't know if a command sequence is imbedded in the raw data, the switch must be set to ignore commands.

Note that these procedures are not needed if the binary file will be transferred from the Slave devices to the Master device. No switching commands are used in the 232BSS4 with data from this direction, so no inadvertent switching can occur.

Method1 – Ignore Commands For a Specific Length of Time

The first method is to ignore commands for a specific length of time. This method is useful if the user knows how long the transfer will take. The Master would first send the command to connect it to the Slave port(s) that are to receive the data. Then the Master device would send the “T” command along with the byte telling the 232BSS4 how long to ignore commands. Once this is sent, data can be transferred to the Slave(s) without the 232BSS4 looking for command sequences. Once the timeout has been reached, the switch will continue looking for



commands and the Master can initiate the next communications sequence.

Example:

For a binary transfer from the Master to the device on Port A that will take less than one second to complete

- Send Select Port A Command: {Char1}{Char2}{Char3}”A”
- Send Ignore Commands Command: {Char1}{Char2}{Char3}”T””5”
- Send the Binary File
- Wait for the timeout period
- Repeat for the next file/port

#### Method2 – Ignore Commands Using DTR

The second method of ignoring command sequences is to set the 232BSS4 to ignore commands if DTR is low from the Master device. This option is enabled through the setup software. This method is useful if the length of the binary file transfers are not known. The user would first raise DTR on the Master device, then send the command to connect it to the Slave port(s) that are to receive the data. Once the command is sent, the Master device would then lower DTR and transmit the data. The 232BSS4 would ignore command sequences and pass them through to any connected ports until DTR was raised.

Example:

For a binary transfer from the Master to the device on Port A

- Raise DTR on the Master Device
- Send Select Port A Command: {Char1}{Char2}{Char3}”A”
- Lower DTR on the Master Device
- Send the Binary File
- Repeat for the next file/port

## **Auto Select/Smart Switch Mode**

### **Description**

Auto Select mode allows the Slave devices to initiate communications with the device connected to the Master port. When Auto Select mode is enabled through the setup software, the 232BSS4 passes data automatically from the Slaves to the Master.

Each Slave port is buffered until the Master is available, then sent in turn. At any time, the Master can reply to the Slaves using the Send to Specific Ports command, or override the automatic switching by selecting a specific port for both transmit and receive.

When the Master device releases the Slave through the Turn Off all ports command, the automatic switching resumes. The 232BSS4 will revert back to the Slave port that was sending data before the Master took over or to the next sequential Slave port with data in its buffer. For a full description of the 232BSS4 commands, refer to the previous section, "Smart Switch Only Mode."

### **Options**

#### **Initial Connections:**

Upon power-up, the 232BSS4 can be initialized to allow the Master to send data to any of the Slave ports without any commands sent. The Master can also be set to broadcast to any or all of the Slave ports on power-up. This allows the switch to be used to add devices to an existing COM port without any software programming. The port initialization is configured through the setup software.

#### **Timeouts:**

When multiple Slave devices are sending data to the Master port at the same time, the 232BSS4 must determine when to stop sending from one Slave port and switch to the next. Two parameters are required to be entered in the setup software for Auto Select mode. The Port Time and Inactivity Time tell the 232BSS4 how much time to spend on each port, and how long a port must be inactive before switching to the next port.

#### **Port Time:**

Setting the Port Time for a value other than zero configures the Master device to receive data from a single port only for the length of time specified during setup. Times are set in milliseconds and can be anywhere in the range of 0 to 65,000 (65 seconds). A value of zero for the Port Time would give the transmitting Slave port access to the Master until an Inactivity Timeout was reached or until a specific Turn Off command was sent from the Master device.

When the specified Port Time has elapsed, the 232BSS4 checks in sequence for other Slave ports with buffered data and switches to them. If no other Slave ports need access to the Master, the current Slave port will again be connected until another Port Time has elapsed.

#### Inactivity Time:

The Inactivity Timer tracks how long a Slave port has been idle. The Inactivity Time is reset any time data is received on the connected Slave port or sent out the Master Port. This way, if the Master port is slower than the connected Slave port, the Slave port is not considered inactive while waiting for the Master to catch up.

Inactivity Time is set through the setup software. Times are set in milliseconds and can be anywhere in the range of 0 to 65,000 (65 seconds). A value of zero for the Inactivity Time would give the transmitting Slave port access to the Master until a Port Timeout was reached or until a specific Turn Off command was sent from the Master device.

#### Port and Inactivity Time Setup Tips:

Normally, the Inactivity Time should be set lower than the Port Time. Setting a zero for either value allows the other to have full control of port switching. Setting a value of zero for both timeouts keeps the Slave port connected until explicitly turned off by the Master device through the Turn Off all ports command.

#### Slave Preamble:

Each Slave can be programmed to transmit a preamble to the Master device when the Slave becomes connected. This tells the Master device which new Slave is sending data. The preamble is set in the setup software and can be any character sequence up to four characters long. The preamble is sent to the Master device whenever a port is selected through commands or when the port will be sending data to the Master device because of an automatic switch.

## Using the 232BSS4 as a Buffered Splitter/Combiner

The Auto Select and Initial Connection features of the 232BSS4 can be used to effectively create a data splitter. Data from the Master device can be shared with multiple Slave devices. Any data coming from the Slaves is buffered so that no data is lost. If the Slave devices already include an address or identifier, no software changes are required.

Figure 2.1 shows a typical configuration allowing several serial terminals access to the same host.

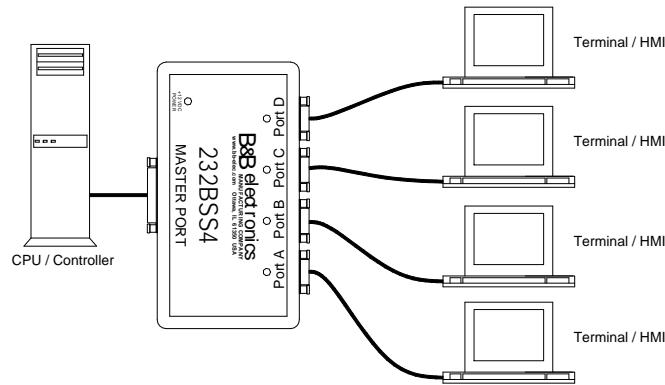
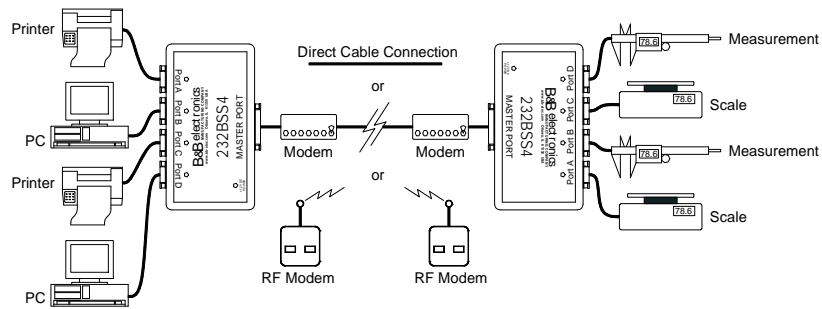

**Figure 2.1. Multiple Terminals to a Host Controller**

To configure the 232BSS4 as a four port splitter/combiner:

- Set up the ports on the 232BSS4 to match the data format of the connected devices. If the Slave devices stream data, the Master port should be set to a higher baud rate than the slaves.
- Set the switches to turn on the Auto Select feature.
- Set the Port Timer to 0. If the Slave devices stream data, the Time per Port may have to be set to a non-zero value.
- Set the Inactivity Timer on all of the switches to somewhere between 20 and 500 milliseconds, depending on the space between data packets and the response time required to each connected device.
- Set the Initial Connections for all ports to receive from the Master on start up.

## Back to Back Operation (mux/demux)



**Figure 2.2. Back to Back Operation**

Two 232BSS4s can be connected together through their Master ports to provide a simple form of multiplexer/demultiplexer. Any Slave port on one switch can automatically send to one or more ports on the other over the single Master port communication channel. The setup software walks the user through the configuration and automatically sets the Slave port preambles.

When two 232BSS4s are connected for Back to Back operation, the Slave ports would typically be set up for a slower baud rate than the Master ports. If the Master ports will not be running at a baud rate at least four times the speed of the Slaves, or if the main Master channel will be connected over a slow communications channel such as through modems, all ports should be configured through the setup software to use hardware handshaking.

Hardware handshaking is automatically turned on for the Master ports when you configure the switches for back to back operation. If you are operating the switches with a direct cable connection or if your communications link does not require handshaking, this option can be turned off in the single unit configuration setup. For details on how to use the setup software, see Chapter 4.

Note that in Back to Back operation the 232BSS4 Master ports will normally be connected to either the Master port of another switch or some type of modem. Because the Master ports are almost always connected to another DCE device, a null modem cable will probably be required. Refer to the cable charts in Appendix B for connecting the Master port to another DCE port.

## Cascading Multiple Switches

If you have more than four devices that are sending data, more than one 232BSS4 can be cascaded, allowing more ports to be added. The 232BSS4 buffers data from all ports at once, making it well suited for devices that will send a fixed amount of data at sporadic intervals, such as measurement instruments, security access card readers, barcode scanners, or time clocks. Below is an explanation of how best to utilize the 232BSS4 to connect these devices to your PC.

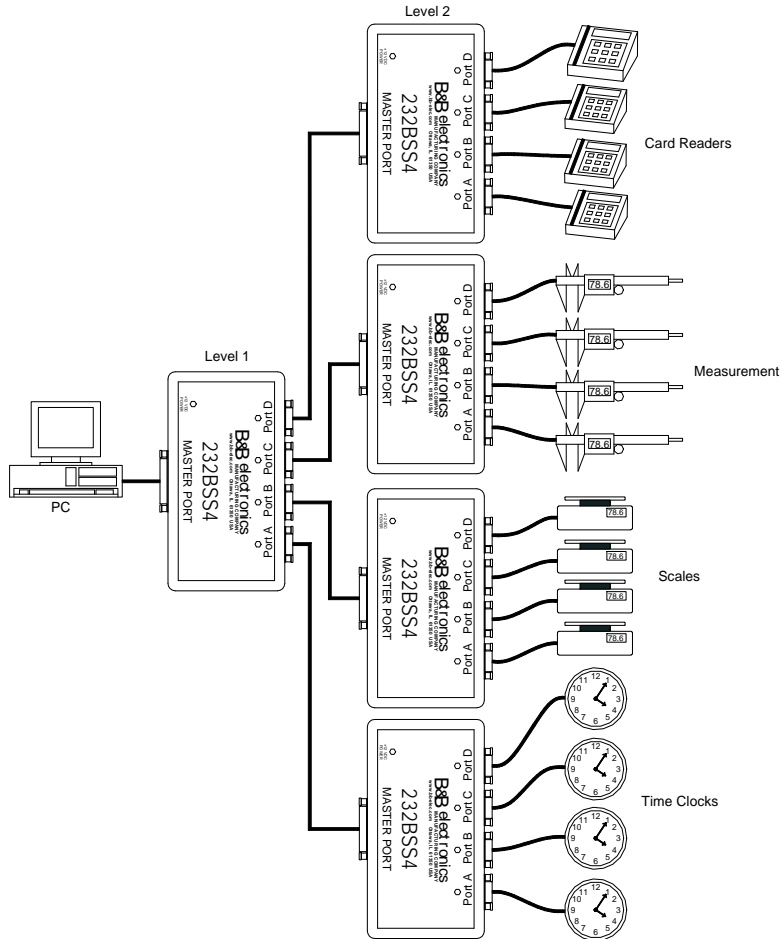

**Figure 2.3. Expanding the Number of Slave Ports**

Figure 2.3 shows a typical setup, with 16 devices sending information at random times to the PC. The switches at Level 2 receive the data and send it on to the Level 1 switch. The Level 1 switch buffers the data and sends it to the PC. Each of the switches will automatically send the data when it is available. If another port has access to the PC, the data will be buffered until a path is available.

#### Slave Devices that Automatically Send their Data:

For best results in an automatic system, the 232BSS4s in the system should be set up the following way.

- Set the switches to turn on the Auto Select feature.
- Set the Port Timer to 0
- Set the Inactivity Timer on all of the switches to somewhere between 20 and 500 milliseconds, depending on the space between data packets and the response time required to each connected device.
- If you need your software to identify which port sent the data, set up the port preamble on the Level 2 switches. Set each port to have a unique preamble. The preamble can be 1, 2, 3, or 4 characters long, and any characters can be used. The preamble will be added to the beginning of each new data packet arriving at the PC. The data collection software on the PC should be written to recognize this preamble as an address or identifier of the data source.

## Slave Devices that Require Polling:

This configuration will also work with systems where the devices have to be polled for information. With the setup of Figure 2.3, the switches can be configured so that you still only have to send one set of switching characters. To do this, set the switches up in the following way:

- Set the switch on Level 1 to broadcast to all slaves on startup.
- Set the switch on Level 1 to Auto Select mode, no preamble.
- Set the switch on Level 1 for 0 Port Time
- Set the switch on Level 1 for a short Inactivity Time. Somewhere around 5 milliseconds or so.
- Set the switches on Level 2 for no Auto Select.
- Set the command sequences on the Level 2 switches to be unique from each other. One suggestion is to use a 3 character command. Use the first character as a start of command character like STX. The second character could represent the address of the Level 2 switch you are going to. The third character is the command character.
- Write the software to send the command to select the port. By setting the Layer 1 switch to broadcast and Auto Select, only 1 set of command characters is needed.

Cascading switches becomes more complicated when the devices are a mix of polled and automatic sending of data. It is also difficult to cascade when devices are streaming data constantly, or automatically sending a variable length packet of data.



## Chapter 3: PORT CONNECTIONS

### DTE/DCE Explanation

In order to determine the proper port connections to the 232BSS4, it is necessary to have a basic understanding of the terms DTE and DCE. RS-232 was designed, using DB-25 connectors, for connecting a DTE (**D**ata **T**erminal **E**quipment) device to a DCE (**D**ata **C**ommunication **E**quipment) device. Each device will have inputs on pins that correspond to outputs on the same pins of the other device. For example, a DTE device will transmit data out on pin 2 (on a DB-25) and a DCE device will receive data in on pin 2 (on a DB-25). IBM PCs and serial printers are DTE devices, modems are DCE devices.

Originally the RS-232 standard specified only a 25 pin D-sub connector. Since then, the use of a 9 pin D-Sub supporting only a portion of the original RS-232 signals has been used extensively, starting with the IBM PC and migrating into other peripherals. The pinouts for this 9 pin connector have since become the EIA/TIA 574 standard. This standard specifies a DTE device that transmits on pin 3 and receives on pin 2, with the DCE having the opposite configuration.

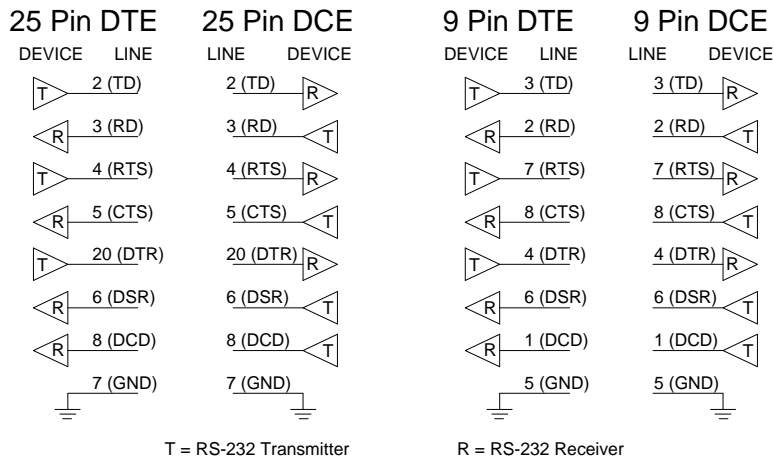

**Figure 3.1. DTE/DCE Port Diagrams**

**Master Port Connections:**

The Master Port of the 232BSS4 is a 25 pin female D-sub connector configured as a DCE. This provides direct connection to an IBM PC compatible or other DTE device. When connecting the Master port to a modem, the Master port of another 232BSS4, or other device configured as a DCE, a null modem adapter such as B&B's model 232DTE is needed. If the user chooses to use the DTR signal to tell the 232BSS4 when to accept commands, the DTR output from the Master device should be connected to pin 20.

See Appendix B for a complete set of connection tables to the 232BSS4 ports.

**Slave Port Connections:**

The Slave Ports of the 232BSS4 are 9-pin, D-sub connectors configured as DTE for direct connection to a modem or other DCE device. When connecting the Slave ports to a PC compatible or other DTE device, a null modem adapter is needed.

See Appendix B for a complete set of connection tables to the 232BSS4 ports.

# Chapter 4: SETUP SOFTWARE

## Introduction

The 232BSS4 comes with simple setup software for configuring the switch. The software can be run on any PC compatible computer running Microsoft Windows 95, 98, NT, 2000, XP or Vista operating system.

Once the switch is configured, all parameters are saved in non-volatile memory so the switch can be powered down and used anywhere without the loss of configuration data. Configurations can also be saved to a file for setting up more than one switch to the same configuration.

## Connection

A serial (COM) port of the computer should be connected to the Master port of the 232BSS4. If the computer's serial port is a 25 pin D-sub, a straight through connection cable is required. If the computer's serial port is a 9-pin D-sub, the cable should be an XT to AT adapter cable such as B&B's model 232CAM, or a cable that would normally be used with a modem. See Appendix B for a complete set of connection tables to the 232BSS4 ports.

Remove the screws (4) on the bottom of the 232BSS4 with a Phillips screwdriver. Remove the top cover. Install the setup jumper marked JP1. See Figure 4.1 for a diagram of the PCBD. Power up the 232BSS4 with the setup jumper installed to put the switch in setup mode. The setup software can not recognize the switch if the setup jumper is not installed or if the jumper is installed after the unit is powered up. Remove the setup jumper when configuration is complete to put the 232BSS4 in normal operating mode.

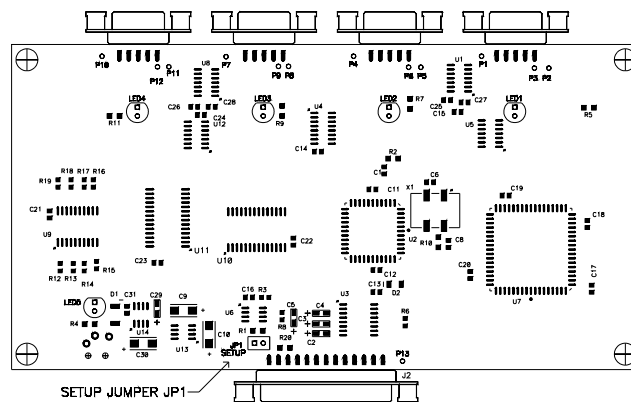

Figure 4.1 Setup Jumper Location

## **Software Installation**

The setup software for the 232BSS4 must be installed on your hard drive before it can be run. All directions assume the CDROM drive is assigned to drive D. If your drive is assigned another drive name, replace that name for D in the instructions. To install on your hard drive follow these steps:

- Place the 232BSS4 setup CDROM in drive D.
- Select **RUN** from the Windows **START** menu.
- Type D:\SETUP and click **OKAY**.
- Follow the instructions in the Installation program.

## **Software Uninstall**

To remove the 232BSS4 setup software, follow these steps:

- Select **SETTINGS, CONTROL PANEL** from the Windows **START** menu.
- Double Click **ADD/REMOVE PROGRAMS**
- Select **BSS4SETUP** from the list of installed programs.
- Click the **ADD/REMOVE** button to remove the software components.

## **Setup Tutorial**

- Step 1: Start the software by double clicking the Smart Switch setup icon on the desktop.
- Step 2: Select the serial (COM) port that will be used to configure the 232BSS4 or Check the box to create a configuration file without the 232BSS4 connected.
- Step 3: Click Next
- Step 4: If you are creating a configuration without a switch connected, proceed to “Single Unit Main screen.” Otherwise, select the way that the 232BSS4 will be used. If the 232BSS4 is going to be used with an intelligent Master device, or if only certain parameters are going to change, select Single Unit operation. If two 232BSS4 switches will be used in a back-to back configuration, select Back to Back.
- Step 5: Connect the 232BSS4 to the COM port selected. Install the setup jumper, and power up the 232BSS4. When Next is clicked, the software reads the current configuration of the connected switch and displays the Main Screen.

### **Single Unit Main Screen:**

All configuration of the 232BSS4 can be initiated from the Main Screen. The overall operation of the switch and each port’s parameters can be individually selected and modified.

**NOTE:** All character values specified in the setup software are given in decimal. For ASCII or Hex equivalents, refer to Appendix A.

### **File Menu:**

From the file menu, a configuration can be saved to disk, loaded from a disk, or printed to the default Windows printer. This provides an easy method of configuring multiple switches with the same setup.

### **Operation Setup:**

When selected, the Operation Setup button displays the parameters associated with the basic operation of the switch. In this screen, the user can set the switch for Smart Switch Only or Auto Select mode. The “Set DTR for Commands” check box configures the 232BSS4 to only accept commands from the Master device if DTR (pin 20) is raised.

The number of command characters is set through a pull-down menu. The first 2/3 command characters are also specified in this section.

When the switch is set for Auto Select mode, the Port Time and Inactivity time must be set. This time is in milliseconds and must be

between 0 and 65000 (65 seconds). See chapter 2 for a full description of these Timeout values.

#### Initial Connections:

When selected, the Initial Connections button provides a selection of ports to be connected when the unit is powered up.

When the switch is set for Smart Switch Only mode (no Auto Select), the Master to Slave communications (individual or broadcast) can be initialized to any or all of the four slave ports. One of the Slaves can also have access to the Master on power-up.

When in Auto Select mode, the Master can still be initialized to transmit data to the Slaves, but Slave to Master communications is handled through automatic switching and cannot be initialized.

#### Master Port Configuration:

This button displays the parameters for the Master Port, including Data Rate, the number of Data Bits, Parity, and if the port requires handshaking.

#### Slave Ports A – D Configuration:

This button displays the parameters for the Slave Port, including Data Rate, the number of Data Bits, Parity, and if the port requires handshaking. The port's preamble characters are also defined here.

#### Read Module Configuration:

This button will read the configuration from the connected 232BSS4. The 232BSS4 is read upon entering the Main Screen, so it should not have to be read again unless it is necessary to set the parameters back after changing.

#### View Module Configuration:

This button will display all current module parameters on one screen for review. Any changes to the currently connected switch that have not been saved will be shown in Red. The page can then be printed to the default Windows printer for review or for attachment to the switch.

**Configure Switch Button:**

This button will save all changes to the connected switch.

**NOTE:** Once changes are saved to the switch they cannot be reset automatically. Be sure to review all changes before saving using the View Module Configuration button.

**Run Self Test:**

The 232BSS4 is programmed with a Self Test mode. The microprocessor checks the UARTs, RAM, and EEPROM and reports any errors back to the setup software. If the software reports an error, contact B&B Technical Support.

**Back to Back Main Screen:**

The Back-to-Back main screen is the same as the Single Unit with a few exceptions. Both modules' parameters are available for viewing at the same time. Also, some parameters are pre-defined and not available to the user.

**File Menu:**

From the file menu, the configuration of both switches can be saved to disk, loaded from a disk, or printed. This provides an easy method of configuring multiple switches with the same setup.

**Operation Setup:**

Back-to-Back units are predefined for Auto Switch mode and a three-character command. The command characters can be set to other than default if the main communications channel cannot accept certain characters. The characters set on Unit #1 are automatically copied to Unit #2. The Port Timeout and Inactivity timer must be set.

**Master Port Configuration:**

The Master port is automatically configured to use Hardware Handshaking. Setting the Baud Rate, Data Bits, and Parity on Unit #1 automatically sets these parameters on Unit #2.

**Ports A-D Configuration:**

All Slave ports on both units can be independently configured for Baud Rate, Data Bits, and Parity. Hardware Handshaking can be enabled or disabled on any of the ports. All automatic connections are established on Unit #1 and any necessary parameters are copied to Unit #2. Any combination of connections is possible.

**Load Configuration:**

The parameters for Unit #1 are automatically loaded when the Back-to-Back main screen is entered. Unit #2 is loaded the first time the Unit

#2 tab is selected. The user should not have to reload the configuration except when the parameters need to be reset to those already saved in the switch. The load configuration button will load the configuration from the connected switch and assume these apply to the selected Unit.

#### View Module Configuration:

Each unit's configuration can be reviewed on one screen by selecting the appropriate tab and clicking the View Module Configuration button. Any changes from what was read from the switch will be shown in red. The page can then be printed to the default Windows printer for review or for attachment to the switch.

#### Configure Switch:

Before exiting the program, all changes should be saved to the switches. The parameters will be saved to the connected switch. Care should be taken to ensure that the correct Unit is connected, its setup jumper installed, and power applied before saving.

**NOTE:** Once changes are saved to the switch they cannot be reset automatically. Be sure to review all changes before saving.



### **Copying Parameters Between Switches:**

The 232BSS4 setup software can save configuration data to a file for copying of parameters. Any unit's setup can be copied by first reading the data from one switch, then saving to another.

- Step 1: Run the setup software.
- Step 2: Select serial (COM) port to be used for programming.
- Step 3: Select Single Unit operation. If the configuration to be used is already saved to a file, skip to Step 8.
- Step 4: Connect the switch to be copied to the serial (COM) port of the PC. Install the setup jumper. Apply power to the 232BSS4.
- Step 5: Click Next.
- Step 6: Select Save As from the File menu. Save the configuration to disk.
- Step 7: Disconnect the first 232BSS4 from the COM port.
- Step 8: Connect the destination switch to the serial (COM) port of the PC. Install the setup jumper. Apply power to the 232BSS4.
- Step 9: Select File/Load File and load the saved configuration.
- Step 10: Click Save Changes

Once the configuration file has been loaded, any number of switches can be set to the same parameters by connecting and configuring each in turn.

### **Default Parameters:**

When shipped, the 232BSS4 comes set up for the following parameters:

- Auto Select mode OFF
- DTR NOT required to accept commands
- THREE-character command
- Char1 = ESC (Decimal 27)
- Char2 = STX (Decimal 2)
- Char3 = "0" (Not Used)
- Port Time = 1,000 mS (Not Used)
- Inactivity Time = 500 mS (Not Used)
- All ports 9600 Baud
- All ports 8 Data Bits
- All ports No Parity
- All ports No Hardware Handshake required
- Ports A-D No preamble
- Port A selected to Transmit & Receive on Power-up



## Appendix A: ASCII Character Codes

DECIMAL to HEX to ASCII CONVERSION TABLE												
DEC	HEX	ASCII	KEY	DEC	HEX	ASCII	DEC	HEX	ASCII	DEC	HEX	ASCII
0	0	NUL	ctrl @	32	20	SP	64	40	@	96	60	`
1	1	SOH	ctrl A	33	21	!	65	41	A	97	61	a
2	2	STX	ctrl B	34	22	"	66	42	B	98	62	b
3	3	ETX	ctrl C	35	23	#	67	43	C	99	63	c
4	4	EOT	ctrl D	36	24	\$	68	44	D	100	64	d
5	5	ENQ	ctrl E	37	25	%	69	45	E	101	65	e
6	6	ACK	ctrl F	38	26	&	70	46	F	102	66	f
7	7	BEL	ctrl G	39	27	'	71	47	G	103	67	g
8	8	BS	ctrl H	40	28	(	72	48	H	104	68	h
9	9	HT	ctrl I	41	29	)	73	49	I	105	69	i
10	A	LF	ctrl J	42	2A	*	74	4A	J	106	6A	j
11	B	VT	ctrl K	43	2B	+	75	4B	K	107	6B	k
12	C	FF	ctrl L	44	2C	,	76	4C	L	108	6C	l
13	D	CR	ctrl M	45	2D	-	77	4D	M	109	6D	m
14	E	SO	ctrl N	46	2E	.	78	4E	N	110	6E	n
15	F	SI	ctrl O	47	2F	/	79	4F	O	111	6F	o
16	10	DLE	ctrl P	48	30	0	80	50	P	112	70	p
17	11	DC1	ctrl Q	49	31	1	81	51	Q	113	71	q
18	12	DC2	ctrl R	50	32	2	82	52	R	114	72	r
19	13	DC3	ctrl S	51	33	3	83	53	S	115	73	s
20	14	DC4	ctrl T	52	34	4	84	54	T	116	74	t
21	15	NAK	ctrl U	53	35	5	85	55	U	117	75	u
22	16	SYN	ctrl V	54	36	6	86	56	V	118	76	v
23	17	ETB	ctrl W	55	37	7	87	57	W	119	77	w
24	18	CAN	ctrl X	56	38	8	88	58	X	120	78	x
25	19	EM	ctrl Y	57	39	9	89	59	Y	121	79	y
26	1A	SUB	ctrl Z	58	3A	:	90	5A	Z	122	7A	z
27	1B	ESC	ctrl [	59	3B	;	91	5B	[	123	7B	{
28	1C	FS	ctrl \	60	3C	<	92	5C	\	124	7C	
29	1D	GS	ctrl ]	61	3D	=	93	5D	]	125	7D	}
30	1E	RS	ctrl ^	62	3E	>	94	5E	^	126	7E	~
31	1F	US	ctrl _	63	3F	?	95	5F	_	127	7F	DEL



## Appendix B: Cable Charts

All charts give full pin outs. Only pins 2 & 3 are required for basic operation. Handshaking pins are needed for hardware (RTS/CTS) handshaking or if DTR is to be used to signal the Master port to accept commands. See Appendix C for a block diagram of the 232BSS4.

### *Master Port Connections:*

**Chart B.1. DTE (PC) DB25 Connector to Master Port**

DTE (PC) Serial Port DB25 Connector	Signal Direction	232BSS4 Master Port (DCE) DB25 Connector
2	----->	2 (TD)
3	<-----	3 (RD)
4	----->	4 (RTS)
5	<-----	5 (CTS)
6	<-----	6 (DSR) *
7	<----->	7 (GND)
8	<-----	8 (DCD) *
20	----->	20 (DTR) *

\* - Pins 6, 8, & 20 looped back internally on the 232BSS4

**Chart B.2. DTE (PC) DB9 Connector to Master Port**

DTE (PC) Serial Port DB9 Connector	Signal Direction	232BSS4 Master Port (DCE) DB25 Connector
1	<-----	8 (DCD) *

2	<-----	(RD)	3
3	----->	(TD)	2
4	----->	(DTR) *	20
5	<----->	(GND)	7
6	<-----	(DSR) *	6
7	----->	(RTS)	4
8	<-----	(CTS)	5

\* - Pins 6, 8, & 20 looped back internally on the 232BSS4

**Chart B.3. DCE (Modem) DB25 Connector to Master Port**

DCE (Modem) Serial Port DB25 Connector	Signal Direction	232BSS4 Master Port (DCE) DB25 Connector
2	<-----	3 (RD)
3	----->	2 (TD)
4	<-----	5 (CTS)
5	----->	4 (RTS)
6	----->	20 (DTR) *
7	<----->	7 (GND)
20	<-----	6 (DSR) *

- - Pins 6, 8, & 20 looped back internally on the 232BSS4

**Chart B.4. DCE (Modem) DB9 Connector to Master Port**

DCE (Modem) Serial Port DB9 Connector	Signal Direction	232BSS4 Master Port (DCE) DB25 Connector
2	----->	2 (TD)
3	<-----	3 (RD)
4	<-----	6 (DSR) *
5	<----->	7 (GND)
6	----->	20 (DTR) *
7	<-----	5 (CTS)
8	----->	4 (RTS)

- - Pins 6, 8, & 20 looped back internally on the 232BSS4

*Slave Port Connections:*

**Chart B.5. Ports A - D (DTE) to DTE (PC) DB25 Connector**

232BSS4 Ports A - D (DTE) DB9 Connector	Signal Direction	DTE (PC) Serial Port DB25 Connector
1 (DCD) *	----->	8
2 (RD)	<-----	2
3 (TD)	----->	3
4 (DTR) *	----->	6
5 (GND)	<----->	7
6 (DSR) *	<-----	20
7 (RTS)	----->	5
8 (CTS)	<-----	4

- \* - Pins 1, 4, & 6 looped back internally on the 232BSS4

**Chart B.6. Ports A - D (DTE) to DTE (PC) DB9 Connector**

232BSS4 Ports A - D (DTE) DB9 Connector	Signal Direction	DTE (PC) Serial Port DB9 Connector
1 (DCD) *	----->	1
2 (RD)	<-----	3
3 (TD)	----->	2
4 (DTR) *	----->	6
5 (GND)	<----->	5
6 (DSR) *	<-----	4
7 (RTS)	----->	8
8 (CTS)	<-----	7

- - Pins 1, 4, & 6 looped back internally on the 232BSS4

**Chart B.7. Ports A - D (DTE) to DCE (Modem) DB25 Connector**

232BSS4 Ports A - D (DTE) DB9 Connector	Signal Direction	DCE (Modem) Serial Port DB25 Connector
---	---------------------	--



1 (DCD) *	<-----	8
2 (RD)	<-----	3
3 (TD)	----->	2
4 (DTR) *	----->	20
5 (GND)	<----->	7
6 (DSR) *	<-----	6
7 (RTS)	----->	4
8 (CTS)	<-----	5

- - Pins 1, 4, & 6 looped back internally on the 232BSS4

**Chart B.8. Ports A - D (DTE) to DCE (Modem) DB9 Connector**

232BSS4 Ports A - D (DTE) DB9 Connector	Signal Direction	DCE (Modem) Serial Port DB9 Connector
1 (DCD) *	<-----	1
2 (RD)	<-----	2
3 (TD)	----->	3
4 (DTR) *	----->	4
5 (GND)	<----->	5
6 (DSR) *	<-----	6
7 (RTS)	----->	7
8 (CTS)	<-----	8

- \* - Pins 1, 4, & 6 looped back internally on the 232BSS4



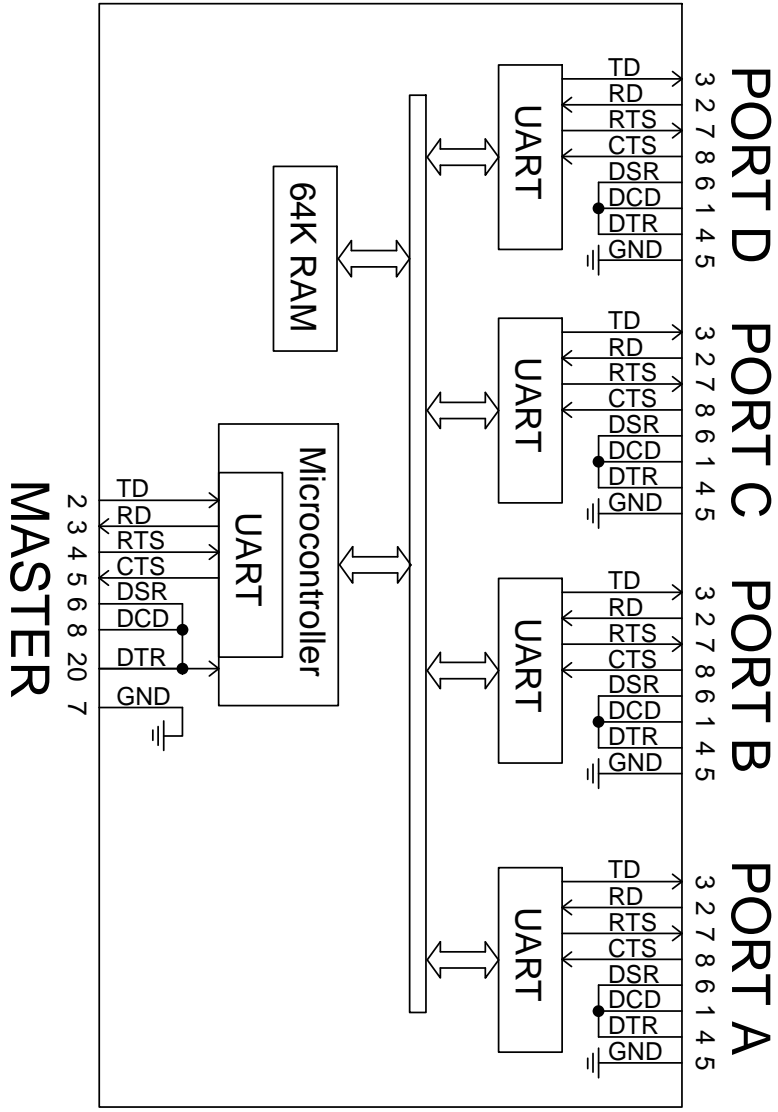

# Appendix C: Block Diagram



**232BSS4 Block Diagram**



## Appendix D: Declaration of Conformity

DECLARATION OF CONFORMITY	
Manufacturer's Name:	B&B Electronics Manufacturing Company
Manufacturer's Address:	P.O. Box 1040 707 Dayton Road Ottawa, IL 61350 USA
Model Numbers:	232BSS4
Description:	RS-232 4-Port Buffered Smart Switch
Type:	Light industrial ITE equipment
Application of Council Directive:	89/336/EEC
Standards:	EN 55022 EN 61000-6-1 EN 61000 (-4-2, -4-3, -4-4, -4-5, -4-6, -4-8, -4-11)
	
William H. Franklin III, Director of Engineering	

Manual Documentation Number: XXXxxx-2305

B-1

B&B Electronics Mfg Co Inc - 707 Dayton Rd - PO Box 1040 - Ottawa IL 61350 - Ph 815-433-5100 - Fax 815-433-5104 - [www.bb-elec.com](http://www.bb-elec.com)  
B&B Electronics - Westlink Commercial Park - Oranmore, Galway, Ireland - Ph +353 91-792444 - Fax +353 91-792445 - [www.bb-europe.com](http://www.bb-europe.com)