



Perle 10/100 Ethernet Media Converter Module

Installation Guide

C-110-XXXXX

Unmanaged Module

CM-110-XXXXX

Managed Module



Overview

This document contains instructions necessary for the installation and operation of the Perle 10/100 Ethernet Media Converter Module(s) (C-110 and CM-110) that are used in conjunction with a Perle MCR Chassis. The C-110 are unmanaged media converter modules, and the CM-110 are the managed versions. These products convert a 10/100Base-T connection (copper) to a 100Base-X connection (fiber). The fiber connection can be either single mode (SM) or multimode (MM) and can operate over different wavelengths and distances, depending on the model (see table below). For information on management features of the CM-110 module, refer to the MCR-MGT Module User's Guide.

Model	Connector	Mode - Distance	Wavelength
C-110-M1ST2U CM-110-M1ST2U	ST	MM - 2 km/1.2 mi.	1310 nm
C-110-M1ST2D CM-110-M1ST2D	ST	MM - 2 km/1.2 mi.	1550 nm
C-110-M2xx2 CM-110-M2xx2	SC/ST/LC	MM - 2 km/1.2 mi.	1310 nm
C-110-M1SC2U CM-110-M1SC2U	SC	MM - 2 km/1.2 mi.	1310 nm
C-110-M1SC2D CM-110-M1SC2D	SC	MM - 2 km/1.2 mi.	1550 nm
C-110-S2xx20 CM-110-S2xx20	SC/ST/LC	SM - 20 km/12.4 mi.	1310 nm
C-110-S2xx40 CM-110-S2xx40	SC/ST/LC	SM - 40 km/24.9 mi.	1310 nm
C-110-S2xx80 CM-110-S2xx80	SC/ST/LC	SM - 80 km/49.7 mi.	1550 nm
C-110-S2xx120 CM-110-S2xx120	SC/ST/LC	SM - 120 km/74.6 mi.	1550 nm
C-110-S1xx20U CM-110-S1xx20U	SC/ST	SM - 20 km/12.4 mi.	1310/1550 nm
C-110-S1xx20D CM-110-S1xx20D	SC/ST	SM - 20 km/12.4 mi.	1550/1310 nm
C-110-S1SC40U CM-110-S1SC40U	SC	SM - 40 km/24.9 mi.	1310/1550 nm
C-110-S1SC40D CM-110-S1SC40D	SC	SM - 40 km/24.9 mi.	1550/1310 nm

Note 2: Please refer the Perle web site for the most up to date Installation guides, models and specifications: <http://www.perle.com/>

Installation

The module comes equipped with a bank of DIP switches and jumpers for setting configuration.

The default dip switch settings (all switches in the UP position) and default jumper settings will work for most installations.

The following steps are used to configure the Perle 10/100 Ethernet Media Converter Module:

1. Set the Auto-MDIX jumper (optional).
2. Set the Auto-Config jumper (CM-110 only) (optional)
3. Set the DIP switch settings (optional).
4. Insert the Media Converter Module into the Chassis.
5. Connect the fiber cable.
6. Connect the copper cable.

Auto-MDIX Jumper

Note: The factory settings for Auto-MDIX will work for most installations, but if there is a need to modify the settings, follow the procedure below.

The AUTO-MDIX jumper (J5) is located on the upper edge, at the midpoint of the module (see diagram below for labelling).. By covering or strapping pins 2 and 3(AUTO), the C-110 and CM-110 will automatically detect the Ethernet cable's polarity and configure itself as either an MDI or an MDIX device. By covering or strapping pins 1 and 2(MDIX), the C-110 and CM-110 will operate as an MDIX device. Removing the strapping is the same as AUTO.

NOTE: The default jumper setting is AUTO

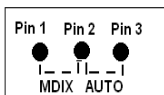

Auto-Config Jumper (CM-110 only)

The Auto-Config jumper (J6) is located just below the Auto-MDIX jumper (see above). Refer to the diagram below for labelling. This jumper only applies to CM-110 modules.

Strapping pins 1 and 2 of the jumper will set the module in SW mode and strapping pins 2 and 3 will set it in Auto Config mode.

Auto: When set to Auto the module will, at power-up, check its internal flash memory to see if configuration information has been downloaded to it from a management module. If so it will use this as its running configuration. If there is no configuration in flash it will read the settings of the DIP switches and use those as its running configuration.

SW: When set to SW (Switch), the module will, at power-up, read the settings of the DIP Switches and use those as its running configuration. It will ignore any configuration information in its flash memory.

NOTE: The default jumper setting is Auto

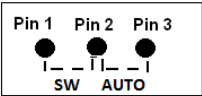

DIP Switches

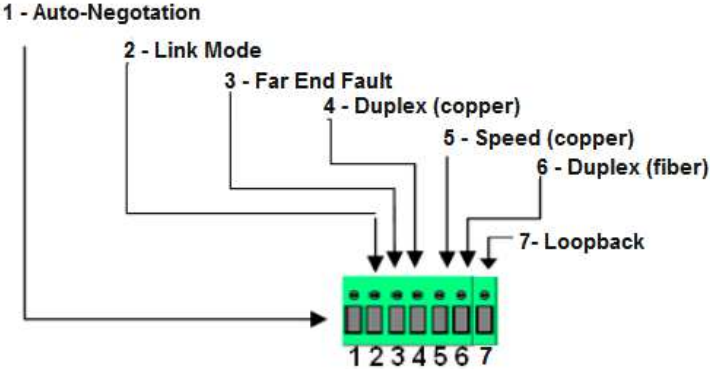

DIP Switch Settings

Auto Negotiation (Switch 1)

Switch Position	Mode
Up (default)	Auto
Down	Off

Note: Auto negotiation should only be turned off, if the copper link partner does not support Auto Negotiation or fixed settings are required by the copper link partner.

Auto: In this mode of operation the Media Converter Module will negotiate Ethernet parameters on the copper connection. This will ensure that the most optimal connection parameters will be used. If the copper link partner does not support Auto negotiation, the Media Converter Module will parallel detect to 10 or 100 Mbps and force Half Duplex mode as per IEEE specifications.

Off: When the Auto Negotiation switch is set to the OFF position, the Media Converter Module will not negotiate the Ethernet parameters

with the copper link partner. The parameters used by the Media Converter Module will be determined by the Duplex (switch 4) and Speed (switch 5) dip switch settings.

Link Mode (Switch 2)

Switch Position	Mode
Up (default)	Link Pass-Through Mode
Down	Standard Mode

Link Pass-Through: In this mode, the link state on one connection is directly reflected through the Media Converter Module to the other connection. If the link is lost on one of the connections, then the other link will be brought down.

With Media Converters on both ends of the fiber link and both setup for Link Pass-Through, a loss of copper link on the far end device will propagate through both Converters and will result in a loss of copper link at the near end device. This would, in effect, resemble a direct copper connection

Standard Mode: In this mode, the links on the fiber and copper sides can be brought up and down independently of each other. A loss of link on either the fiber or copper port can occur without affecting the other connection.

Far End Fault (Switch 3)

Switch Position	Mode
Up (default)	Enabled
Down	Disabled

Enabled: If the Media Converter Module detects a loss of receive fiber signal, it will transmit a FEF signal to the remote Media Converter. This, in effect, notifies the fiber link partner that an error condition exists on the fiber connection.

If the remote Media Converter is set up for Far End Fault (FEF) and the local Media Converter is set up with Link Pass-Through, a loss of

fiber link on either the transmit or receive line will be passed through to the local copper connection thus notifying the connected device.

If the Media Converter has been set to Link Pass-Through mode, the effect will be the same as FEF, since the link loss on the fiber receiver will result in bringing down the copper link, which will in turn cause the transmit fiber link to be brought down.

Note: If it is required to either generate or detect the FEF signal, then the FEF switch needs to be set.

Disabled: The Media Converter Module will not monitor for or generate Far End Fault.

The following diagram is an illustration of the operation of this feature.

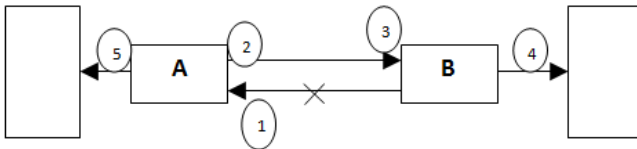

(A) – Remote Media Converter setup for Far End Fault Enabled, Auto Negotiation – OFF and Link Mode – Standard.

(B) – Local Media Converter setup for Far End Fault - Enabled, Link Pass-Through - On and Auto Negotiation - OFF

- 1 – **(A)** Loses fiber connection on its receiver.
- 2 – **(A)** Sends FEF.
- 3 – **(B)** Detects FEF signal and shuts down the fiber link.
- 4 – **(B)** Drops link on copper connection because Link Pass-Through is configured.
- 5 – **(A)** Link on copper connection is not affected because Link Mode is set to Standard.

Duplex (copper) (Switch 4)

Switch Position	Mode
Up (default)	Full
Down	Half

Note: When Auto Negotiation (SW1) is set to Off, the Media Converter will use this Duplex setting for its copper connection.

Up: The Media Converter Module will be set to Full Duplex mode.

Down: The Media Converter Module will be set to Half Duplex mode.

Speed (copper) (Switch 5)

Switch Position	Mode
Up (default)	100
Down	10

Note: When Auto Negotiation (SW1) is set to Off, the Media Converter Module will use this Speed setting for its Ethernet copper connection.

Up: The Media Converter will be fixed at 100 Mbps.

Down: The Media Converter will be fixed at 10 Mbps.

Duplex (fiber) (Switch 6)

Switch Position	Mode
Up (default)	Full
Down	Half

Up: The Media Converter Module's fiber link will be set to Full Duplex Mode.

Down: The Media Converter Module's fiber will be set to Half Duplex Mode.

Loopback (Switch 7)

Switch Position	Mode
Up (default)	Disabled
Down	Enabled

Disabled: This is the setting for normal operation. The switch must be set to this position in order for data to pass through the Media Converter Module.

Enabled: This is a test mode. All data received on the receive (RX) fiber connection is looped back to the transmit (TX) fiber connection. The state of the copper link is not relevant since no data is passed through to the copper side. This mode will override all other switch settings.

Installing or Replacing Media Converter Modules

Caution: *Observe electrostatic discharge precautions when installing the Media Converter Module(s) into the Chassis. Failure to observe this caution could result in damage to the Media Converter Module(s) and /or chassis.*

The Perle Media Converter Modules can be installed in any available slot and in any order within the Chassis.

Installing or Replacing a Media Converter Module

1. Remove the Media Converter Module from its packaging.
2. Using a cross-head screwdriver, remove the screw holding the face plate to the Chassis to reveal the slot opening.
3. Set the jumpers and DIP switches on the Media Converter Module to the desired operating mode.
4. Locate the top and bottom alignment guides inside the Chassis.
5. Using the module alignment guides gently slide the module into the slot until it becomes flush with the front of the Chassis. Light pressure may be needed to seat the module. Do not force the module as you might cause some damage. If there is resistance, remove the module, check the module connector for damaged or incorrectly aligned pins, if there is no damage, retry module insertion.

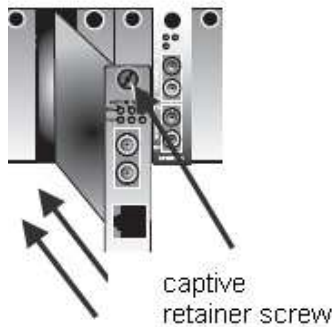

6. Tighten the captive retainer screw to ensure the Media Converter Module is locked in place.
7. Remove the dust cap from the fiber connector and connect the fiber and copper cables.

Removing Media Convert Modules

1. Loosen the captive retainer screw on the front of the Media Converter Module and gently pull the Media Converter Module out.
2. If not inserting a replacement, cover the opened slot with a face plate and secure the screw

Installing the Duplex Fiber Cable

Locate a 100Base-X compliant duplex (2 strands) fiber cable with appropriate connectors.

Connect the fiber cables from the Media Converter Module to the other Media Converter/switch/fiber device ensuring that the RX and TX are reversed (crossed) at the opposite end.

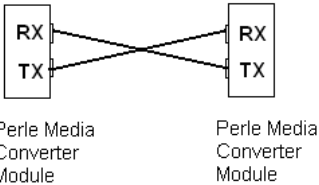

Installing the Simplex Fiber Cable

- Locate a 10/100Base-X compliant simplex (1 strand) fiber cable with appropriate connectors.
- Connect the fiber cable from one Media Converter Module to the other Media Converter/switch/fiber device.

Installing the Copper Cable

- Locate 10/100Base-T compliant copper cables with male, RJ-45 connectors installed at both ends.
- Connect the RJ-45 cable between the Perle Media Converter Module and the device.

Note: The Perle Media Converter Module supports Auto-MDIX which allows a straight-through or cross-over Ethernet cable. See page 4 in this guide for jumper positions.

Operation

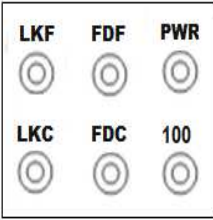

Status LED

The Perle 10/100 Ethernet Media Converter Modules have six single color status LEDs located on the face plate of the module.

<p>PWR <i>On</i> – Power is on; module is operating normally <i>Blinking (slow)</i> – The module is in Loopback mode. <i>Blinking (fast)</i> – The module has a hardware failure.</p> <p>FDF (fiber) <i>On</i> – Full Duplex Mode. <i>Off</i> – Half Duplex Mode.</p> <p>LKF (fiber) <i>On</i> – The fiber link is present <i>Off</i> – No fiber link is present. <i>Blinking (fast)</i> – The fiber link is present and receiving data.</p>	<p>100 (copper speed) <i>On</i> – 100 Mbps <i>Off</i> – 10 Mbps</p> <p>FDC (copper) <i>On</i> – Full Duplex Mode. <i>Off</i> – Half Duplex Mode.</p> <p>LKC (copper) <i>On</i> – The copper link is present. <i>Off</i> – No copper link present. <i>Blinking (fast)</i> – The copper link is present and receiving data.</p>
--	--

Other Features

Auto-MDIX:

Auto-MDIX (automatic medium-dependant interface crossover) detects the signalling on the 10/100BASE-T interface to determine the type of cable connected (straight-through or crossover) and automatically configures the connection.

Error Recovery:

In certain configurations, and under specific conditions where the Media Converter Module brings down a link to convey status, there is potential for a deadlock. Recovery is achieved by momentarily restoring the link to see if the original failure has been resolved. If it has not, the link will be forced down again, however if the original problem has been resolved, the link will be restored.

Pause (IEEE 802.3xy):

Integrated Pause signalling is an IEEE feature that temporarily suspends data transmission between two devices in the event that one of the devices becomes overwhelmed. The Perle Media Converter Module can generate and respond to Pause messages.

Troubleshooting

General

- Ensure that the Media Converter Module is securely seated in the chassis. The PWR LED should be on.
- Ensure both devices on either end of the fiber are compatible. If using a simplex fiber connection, ensure that you have both an Upstream (U) and Downstream (D) Media Converter.
- Ensure all cabling is of the correct type and is in good working order.
- For duplex fiber connections, ensure the RX and TX has been reversed between the two Media Converters.

No connectivity

If unable to get full connectivity with all DIP switches in the UP position, these methods are recommended for troubleshooting.

Method 1

1. If the Module is a CM-110, set the Auto-Config jumper (J6) to SW so that DIP switches are being read.
2. Set the Link mode to Standard (SW2 – Down) on both Media Converters. Leave all other switches in the Up position.
3. Connect the near end device to the copper connection. The LKC LED indicates good copper connection. If the LKC LED is not lit, then check the copper cable and the attached device. Repeat for the far end Media Converter.
4. Connect the fiber cable to both Converters. The LKF LED indicates good fiber connection. If no LKF LED then check the fiber cabling.
5. Return converters to desired configuration.

Method 2:

The fiber connection can also be verified by configuring the remote Media Converter for loopback mode. The LKF LEDs on both Media Converters should be lit. Data should pass through the local converter, over the fiber connection to the remote Media Converter. At the remote Media Converter, the data will be looped back and passed through the fiber, once again, to pass through the local converter to the copper link.

Note: If troubleshooting a CM-110, setting the Auto-Config jumper (J6) to SW will ensure the DIP switches are being read.

Technical Specifications

Power Input/Consumption	12V DC / 2.1 W
Operating Temperature:	0 °C to 50 °C (32 °F to 122 °F)
Storage Temperature:	-25 °C to 70 °C (-13 °F to 158 °F)
Operating Humidity:	5% to 90% non-condensing
Storage Humidity:	5% to 95% non-condensing
Operating Altitude:	Up to 3,048 m (10,000 ft)
MTBF: (C-110)	577,872 hours
(CM-110)	561,817 hours

Fiber Optic Specifications:

Model	Mode	Wavelength (nm)	TX Power (dB)	RX Power (dB)	Budget (dB)
C-110-M1ST2U CM-110-M1ST2U	MM	TX: 1310 RX: 1550	Min: -15 Max: -8	Min: -3 Max: -34	12
C-110-M1ST2D CM-110-M1ST2D	MM	TX: 1550 RX: 1310	Min: -15 Max: -8	Min: -3 Max: -34	12
C-110-M2SC2 CM-110-M2SC2	MM	TX: 1310 RX: 1310	Min: -20 Max: -12	Min: -31 Max: -14	11
C-110-M1SC2U CM-110-M1SC2U	MM	TX: 1310 RX: 1550	Min: -15 Max: 0	Min: -28 Max: -8	13
C-110-M1SC2D CM-110-M1SC2D	MM	TX: 1550 RX: 1310	Min: -15 Max: 0	Min: -28 Max: -8	13
C-110-M2ST2 CM-110-M2ST2	MM	TX: 1310 RX: 1310	Min: -20 Max: -12	Min: -31 Max: -14	11
C-110-M2LC2 CM-110-M2LC2	MM	TX: 1310 RX: 1310	Min: -20 Max: -12	Min: -30 Max: -14	10
C-110-S2SC20 CM-110-S2SC20	SM	TX: 1310 RX: 1310	Min: -18 Max: -7	Min: -32 Max: -3	14
C-110-S2ST20 CM-110-S2ST20	SM	TX: 1310 RX: 1310	Min: -15 Max: -8	Min: -32 Max: -3	17
C-110-S2LC20 CM-110-S2LC20	SM	TX: 1310 RX: 1310	Min: -15 Max: 0	Min: -34 Max: -5	19
C-110-S2SC40 CM-110-S2SC40	SM	TX: 1310 RX: 1310	Min: -5 Max: 0	Min: -34 Max: -3	29
C-110-S2ST40 CM-110-S2T40	SM	TX: 1310 RX: 1310	Min: -5 Max: 0	Min: -34 Max: -3	29

C-110-S2LC40 CM-110-S2LC40	SM	TX: 1310 RX :1310	Min: -5 Max: 0	Min: -34 Max: -3	29
C-110-S2SC80 CM-110-S2SC80	SM	TX: 1550 RX: 1550	Min: -5 Max: 0	Min: -34 Max: -3	29
C-110-S2ST80 CM-110-S2ST80	SM	TX: 1550 RX: 1550	Min: -5 Max: 5	Min: -34 Max: -3	29
C-110-S2LC80 CM-110-S2LC80	SM	TX: 1550 RX: 1550	Min: -5 Max: 0	Min: -34 Max: -3	29
C-110-S2SC120 CM-110-S2SC120	SM	TX: 1550 RX: 1550	Min: 0 Max: 5	Min: -35 Max: -3	35
C-110-S2ST120 CM-110-S2ST120	SM	TX: 1550 RX: 1550	Min: 0 Max: 5	Min: -35 Max: 0	35
C-110-S2LC120 CM-110-S2LC120	SM	TX: 1550 RX: 1550	Min: 0 Max: 5	Min: -35 Max: -3	35
C-110-S1SC20U CM-110-S1SC20U	SM	TX: 1310 RX: 1550	Min: -14 Max: -8	Min: -32 Max: -3	18
C-110-S1SC20D CM-110-S1SC20D	SM	TX: 1550 RX:1310	Min: -14 Max: -8	Min: -32 Max: -3	18
C-110-S1ST20U CM-110-S1ST20U	SM	TX: 1310 RX: 1550	Min: -15 Max: -3	Min: -3 Max: -34	12
C-110-S1ST20D CM-110-S1ST20D	SM	TX: 1550 RX:1310	Min: -15 Max: -3	Min: -3 Max: -34	12
C-110-S1SC40U CM-110-S1SC40U	SM	TX: 1310 RX:1550	Min: -8 Max: -3	Min: -33 Max: -3	25
C-110-S1SC40D CM-110-S1SC40D	SM	TX: 1550 RX:1310	Min: -8 Max: -3	Min: -33 Max: -3	25

Fiber Cabling Requirements:

MM: 50/125 microns or

62.5/125 microns

SM: 9/125 microns

Ethernet Copper Cabling Requirements:

- Category 5 UTP or STP
- 24-22 AWG
- Straight through or Ethernet crossover

Compliance Information

FCC

This product has been found to comply with the limits for a Class A digital device, pursuant to Part 15 of the FCC rules. These limits are designed to provide reasonable protection against harmful interference when the equipment is operated in a commercial environment. This equipment generates, uses, and can radiate radio frequency energy and, if not installed and used in accordance with the instructions in this Guide, may cause harmful interference to radio communications. Operation of this equipment in a residential area is likely to cause harmful interference, in which case the user will be required to correct the interference at his/her own expense.

EN 55022, Class A

WARNING This is a Class A product. In a domestic environment this product may cause radio interference in which case the user may be required to take adequate measures.

EN 55024, Class A

Laser Safety – IEC 60825-1:2007

This product meets Class I Laser safety requirements per IEC-60825-1:2007 standard and complies with FDA/CDRH 21 CFR1040.10 and 21 CFR1040.11.

WARNING: Visible and invisible laser radiation may be present when cables are not connected. Do not stare into the beam or view the beam directly with optical instruments. Failure to observe this warning could result in an eye injury or blindness.

WARNING: Use of controls, adjustments or the performance of procedures other than those specified herein may result in hazardous radiation exposure.

Warranty / Registration

Perle's standard Lifetime Warranty provides customers with return to factory repairs for Perle products that fail under the conditions of the warranty coverage. Details can be found at:

http://www.perle.com/support_services/warranty.shtml

Contacting Technical Support

Contact information for the Perle Technical Assistance Center (PTAC) can be found at the link below. A Technical Support Query may be made via this web page.

www.perle.com/support_services/support_request.shtml

Copyright

© 2010-2015 **Perle Systems Limited**

All rights reserved. No part of this document may be reproduced or used in any form without written permission from Perle Systems Limited.