

PCI-1718 Series

**12-bit Multifunction Cards with
Universal PCI Bus**

User Manual

Copyright

The documentation and the software included with this product are copyrighted 2005 by Advantech Co., Ltd. All rights are reserved. Advantech Co., Ltd. reserves the right to make improvements in the products described in this manual at any time without notice. No part of this manual may be reproduced, copied, translated or transmitted in any form or by any means without the prior written permission of Advantech Co., Ltd. Information provided in this manual is intended to be accurate and reliable. However, Advantech Co., Ltd. assumes no responsibility for its use, nor for any infringements of the rights of third parties, which may result from its use.

Acknowledgements

Intel and Pentium are trademarks of Intel Corporation.

Microsoft Windows and MS-DOS are registered trademarks of Microsoft Corp.

All other product names or trademarks are properties of their respective owners.

This Manual Covers the Following Models

- PCI-1718HDU
- PCI-1718HGU

Part No. 2003171801

2nd Edition

Printed in Taiwan

Nov 2005

Product Warranty (2 years)

Advantech warrants to you, the original purchaser, that each of its products will be free from defects in materials and workmanship for two years from the date of purchase.

This warranty does not apply to any products which have been repaired or altered by persons other than repair personnel authorized by Advantech, or which have been subject to misuse, abuse, accident or improper installation. Advantech assumes no liability under the terms of this warranty as a consequence of such events.

Because of Advantech's high quality-control standards and rigorous testing, most of our customers never need to use our repair service. If an Advantech product is defective, it will be repaired or replaced at no charge during the warranty period. For out-of-warranty repairs, you will be billed according to the cost of replacement materials, service time and freight. Please consult your dealer for more details.

If you think you have a defective product, follow these steps:

1. Collect all the information about the problem encountered. (For example, CPU speed, Advantech products used, other hardware and software used, etc.) Note anything abnormal and list any onscreen messages you get when the problem occurs.
2. Call your dealer and describe the problem. Please have your manual, product, and any helpful information readily available.
3. If your product is diagnosed as defective, obtain an RMA (return merchandise authorization) number from your dealer. This allows us to process your return more quickly.
4. Carefully pack the defective product, a fully-completed Repair and Replacement Order Card and a photocopy proof of purchase date (such as your sales receipt) in a shippable container. A product returned without proof of the purchase date is not eligible for warranty service.
5. Write the RMA number visibly on the outside of the package and ship it prepaid to your dealer.

CE

This product has passed the CE test for environmental specifications when shielded cables are used for external wiring. We recommend the use of shielded cables. This kind of cable is available from Advantech. Please contact your local supplier for ordering information.

Technical Support and Assistance

Step 1. Visit the Advantech web site at **www.advantech.com/support** where you can find the latest information about the product.

Step 2. Contact your distributor, sales representative, or Advantech's customer service center for technical support if you need additional assistance. Please have the following information ready before you call:

- Product name and serial number
- Description of your peripheral attachments
- Description of your software (operating system, version, application software, etc.)
- A complete description of the problem
- The exact wording of any error messages

Packing List

Before setting up the system, check that the items listed below are included and in good condition. If any item does not accord with the table, please contact your dealer immediately.

- PCI-1718HDU/HGU DA&C card
- PCI-1718HDU/HGU User Manual
- Companion CD-ROM with DLL drivers

Safety Precaution - Static Electricity

Follow these simple precautions to protect yourself from harm and the products from damage.

1. To avoid electrical shock, always disconnect the power from your PC chassis before you work on it. Don't touch any components on the CPU card or other cards while the PC is on.
2. Disconnect power before making any configuration changes. The sudden rush of power as you connect a jumper or install a card may damage sensitive electronic components.

Contents

Chapter 1	Introduction	2
1.1	Features	3
1.2	Applications	4
1.3	Installation Guide	5
	Figure 1.1:Installation Flow Chart	6
1.4	Software Overview	7
1.5	Device Driver Programming Roadmap	8
1.6	Accessories.....	10
Chapter 2	Installation	12
2.1	Unpacking	12
2.2	Driver Installation	13
	Figure 2.1:Setup Screen of Advantech Automation Software 14	
	Figure 2.2:Different Options for Driver Setup	14
2.3	Hardware Installation.....	15
2.4	Device Setup & Configuration	16
	Figure 2.3:The Device Manager Dialog Box	16
	Figure 2.4:The Device Setting Dialog Box	17
	Figure 2.5:Device Name Appearing on the List of Devices Box 17	
	Figure 2.6:The Test Utility Dialog Box	18
Chapter 3	Signal Connections	20
3.1	Overview	20
3.2	Switch and Jumper Settings	20
	Figure 3.1:Card Connector, Jumper and Switch Locations 20	
3.2.1	Setting the BoardID Switch (SW1)	21
	Table 3.1:Board ID Setting (SW1)	21
3.2.2	Channel Configuration, S/E or DIFF (SW2)	22
	Table 3.2:Summary of Switch SW2 Settings	22
3.2.3	D/A Reference Voltage, int./ext. (JP11)	22
	Table 3.3:Summary of Jumper JP11 Settings	22
3.2.4	Internal Voltage Reference, -10 V or -5 V (JP10)	23
	Table 3.4:Summary of Jumper JP10 Settings	23
3.2.5	Timer Clock Selection (JP8)	24
	Table 3.5:Summary of Jumper JP8 Settings	24
3.2.6	Ext. trigger and Counter Gate 0 Control (JP5)	25
	Table 3.6:Summary of Jumper Settings	25
3.2.7	Digital Output, 20-pin or 37-pin Connector (JP1)	25
	Table 3.7:Summary of Jumper Settings	26
3.2.8	Setting the Time to Reset Digital Outputs	27
	Table 3.8:JP21 Jumper Settings	27
3.3	Signal Connections.....	28
	Figure 3.2:I/O Connector Pin Assignments for the PCI-	

3.3.1	I/O Connector Signal Description	29
	Table 3.9:I/O Connector Signal Descriptions	29
3.3.2	Analog Input Connections	30
	Figure 3.3:Analog Output Connections	33
3.3.3	Digital Signal Connections	34
3.4	Field Wiring Considerations	35
Chapter 4	Programming Guide	38
4.1	Overview	38
4.2	Programming with the Driver	38
4.3	Register Programming	38
4.3.1	Software Trigger and Polling	39
4.3.2	Pacer Trigger Mode with Interrupt	41
4.3.3	Pacer Trigger Mode with Interrupt and FIFO	45
4.4	Programming with LabVIEW and ActiveDAQ	49
Appendix A	Specifications	52
A.1	Analog Input	52
A.2	Analog Output	53
A.3	Digital Input	54
A.4	Digital Output	54
A.5	Counter/Timer	55
A.6	General	56
Appendix B	Block Diagrams	58
Appendix C	Register Structure & Format	60
C.1	Overview	60
C.2	I/O Port Address Map	60
	Table C.1:PCI-1718HDU/HGU Register Format (Part 1)	61
	Table C.2:PCI-1718HDU/HGU Register Format (Part 2)	62
	Table C.3:PCI-1718HDU/HGU Register Format (Part 3)	63
C.3	A/D Data and Channels — BASE+00H~01H	64
	Table C.4:Register for A/D Data and Channels	64
C.4	Software A/D Trigger — BASE+00H	64
	Table C.5:Register for Software A/D Trigger	64
C.5	A/D Range Control — BASE+01H	65
	Table C.6:Register for A/D Range Control	65
C.6	MUX Scan Channel Control — BASE+02H	67
	Table C.7:Register for MUX Scan Channel Control ...	67
C.7	MUX Scan Channel Status — BASE+02H	68
	Table C.8:Register for MUX Scan Channel Status	68
C.8	Digital I/O Registers - BASE + 03/0BH	68
	Table C.9:Register for Digital Output	68
	Table C.10:Register for Digital Output	69
C.9	D/A Output — BASE+04/05H	69
	Table C.11:Register for D/A Output	69
C.10	FIFO Interrupt Control — BASE+06H	70

	Table C.12: Register for FIFO Interrupt Control	70
C.11	Clear Interrupt Request — BASE+08H	71
	Table C.13: Register for Clear Interrupt Request	71
C.12	A/D Status — BASE+08H	71
	Table C.14: Register for A/D Status	71
C.13	A/D Control — BASE+09H	73
	Table C.15: Register for A/D Control	73
C.14	Timer/Counter Enable — BASE+0AH	74
	Table C.16: Register for Timer/Counter Enable	74
C.15	Programmable Timer/Counter — BASE+0C~0FH	74
C.16	Clear FIFO Interrupt Request — BASE+14H	75
	Table C.17: Register for Clear FIFO Interrupt Request	75
C.17	A/D Data and Channel from FIFO - BASE + 17/18H	75
	Table C.18: Register for A/D Data and Channel from FIFO 75	75
C.18	FIFO Status — BASE+19H	76
	Table C.19: Register for FIFO Status	76
C.19	FIFO Clear — BASE+19H	76
	Table C.20: Register for FIFO Clear	76
C.20	Register Programming Flow Chart	77
	C.20.1 Software Trigger Mode with Polling	77
	C.20.2 Pacer Trigger Mode with Interrupt	78
	C.20.3 Pacer Trigger Mode with Interrupt [FIFO Used]	79
Appendix D	Calibration	82
D.1	VR Assignment	83
	Figure D.1: PCI-1718 VR Assignment	83
D.2	A/D Calibration	84
D.3	D/A Calibration	85

Introduction

This chapter introduces the PCI-1718 cards and their typical applications.

Sections include:

- Features
- Applications
- Installation Guide
- Software Overview
- Device Driver Programming Roadmap
- Accessories

Chapter 1 Introduction

Thank you for buying the Advantech PCI-1718HDU/HGU. PCI-1718HDU/HGU is a PCI-Bus multifunction card for IBM PC/XT/AT or compatible computers. It offers the five most desired measurement and control functions:

- 12-bit A/D conversion
- D/A conversion
- Digital input
- Digital output
- Timer/counter.

A programmable-gain instrument amplifier lets you acquire different input signals without external signal conditioning. An onboard 1 K word FIFO buffer provides high-speed data transfer and predictable performance under Windows. Automatic channel scanning circuitry and onboard SRAM let you perform multiple-channel A/D conversion with DMA and individual gains for each channel.

PCI-1718HDU/HGU is compatible* with its ISA-Bus predecessor, the PCL-818HD/HG. This puts rich software support and a wide variety of external signal conditioning boards at your disposal.

The following sections of this chapter will provide further information about features of the multifunction cards, a Quick Start for installation, together with some brief information on software and accessories for the PCI-1718 cards.

Note*

1. *PCI-1718HDU/HGU is register-level- programming compatible with PCL-818HD/HG*
2. *Due to the difference between ISA and PCI architecture, we use "interrupt + FIFO" to emulate the DMA function. But it makes no difference to your programming and applications.*

1.1 Features

- Register level programming compatible with PCL-818HD/HG
- 16 single-ended or 8 differential A/D inputs, switch selectable
- 12-bit A/D converter, up to 100 kHz sampling rate
- Programmable gain for each input channel
- Automatic Channel/Gain Scanning
- On-board 1 K word FIFO buffer with software selectable interrupt
- Software selectable Bipolar/Unipolar analog input ranges
- 16 digital inputs and 16 digital outputs, TTL/DTL compatible
- One 12-bit analog output channel
- Data transfers by program control and interrupt handler routine
- Universal PCI-Bus (Support 3.3V or 5V PCI-Bus signal)
- BoardID switch

PCI-1718H DU/HGU offers the following main features:

PCI-Bus Plug & Play

The PCI-1718 cards use a PCI controller to interface the card to the PCI bus. The controller fully implements the PCI bus specification Rev 2.2. All configurations related to the bus, such as base address and interrupt assignment, are automatically controlled by software. No jumper or switch is required for user configuration.

Automatic Channel/Gain Scanning

PCI-1718H DU/HGU features an automatic channel/gain scanning circuit. This circuit, instead of your software, controls multiplexer switching during sampling. On-board SRAM stores different gain values for each channel. This combination lets user perform multi-channel high-speed sampling (up to 100 kHz) for each channel.

Onboard FIFO

There are 1 K samples FIFO for A/D (AI) on PCI-1718HDU/HGU. This is an important feature for faster data transfer and more predictable performance under Windows system.

Onboard Programmable Timer/Counter

PCI-1718HDU/HGU provides a programmable timer counter for generating pacer trigger for the A/D conversion. The timer/counter chip is 82C54, which includes three 16-bit counters of 10 MHz clock. One counter is used as an event counter for counting events coming from the input channel. The other two are cascaded together to make a 32-bit timer for pacer trigger time base.

BoardID Switch

PCI-1718HDU/HGU has a built-in DIP switch that helps define each card's ID when multiple PCI-1718HDU/HGU cards have been installed on the same PC chassis. The BoardID setting function is very useful when building a system with multiple PCI-1718 cards. With the correct BoardID settings, you can easily identify and access each card during hardware configuration and software programming.

Note: For detailed specifications of the PCI-1718HDU/HGU, please refer to Appendix A.

1.2 Applications

- Transducer and sensor measurements
- Waveform acquisition and analysis
- Process control and monitoring
- Vibration and transient analysis

1.3 Installation Guide

Before you install your PCI-1718HDU/HGU card, please make sure you have the following necessary components:

- PCI-1718HDU/HGU DA&C card
- PCI-1718HDU/HGU User Manual
- Driver software Advantech DLL drivers (included in the companion CD-ROM)
- Personal computer or workstation with a PCI-bus slot (running Windows 98/2000/XP)
- PCL-10120 or PCL-10137 Wiring cable (optional)
- ADAM-3920/3937, PCLD-7216/780/782/782B/785/785B/786/788/789D/880/885/8115 Wiring board (optional)

Some other optional components are also available for enhanced operation:

- ActiveDAQ, ADAQView, LabView or other third-party software packages

After you get the necessary components and maybe some of the accessories for enhanced operation of your multifunction card, you can then begin the installation procedure. Figure 1.1 on the next page provides a concise flow chart to give users a broad picture of the software and hardware installation procedures:

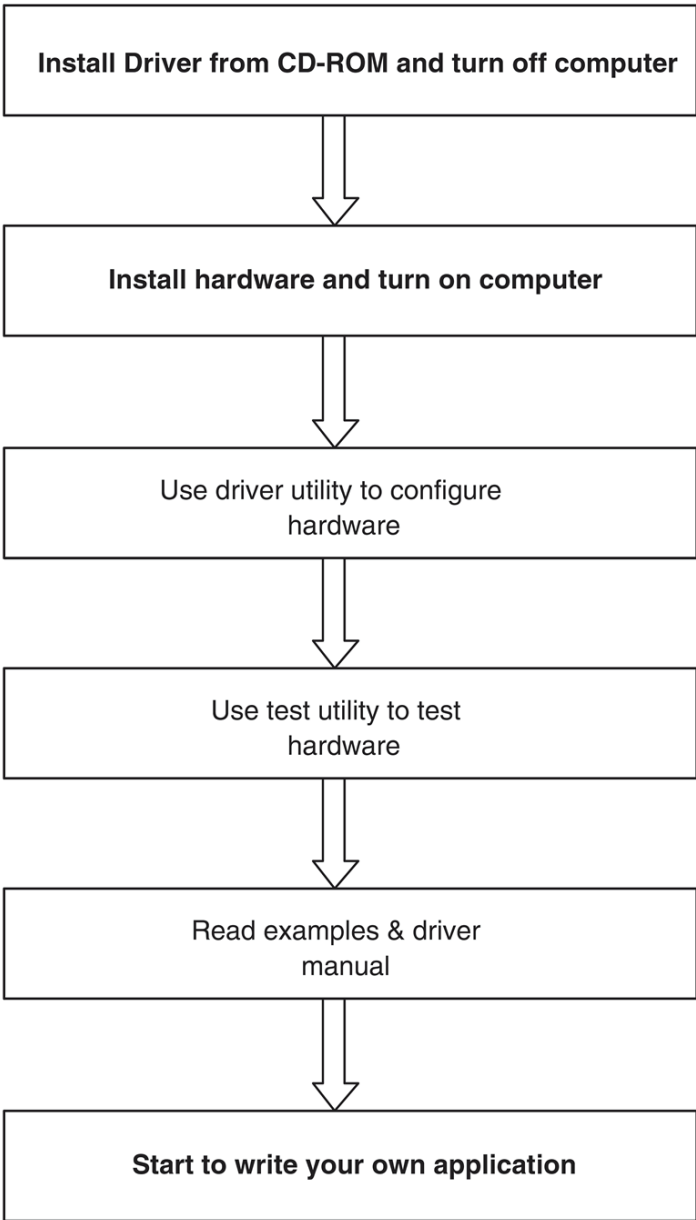

Figure 1.1: Installation Flow Chart

1.4 Software Overview

Advantech offers a rich set of DLL drivers, third-party driver support and application software to help fully exploit the functions of your PCI-1718HDU/HGU card:

- Device Drivers (on the companion CD-ROM)
- LabVIEW driver
- Advantech ActiveDAQ
- Advantech ADAQView

Programming choices for DA&C cards

You may use Advantech application software such as Advantech Device Drivers. On the other hand, advanced users can use register-level programming, although this is not recommended due to its laborious and time-consuming nature.

Device Drivers

Advantech Device Driver software is included on the companion CD-ROM at no extra charge. It also comes with all Advantech DA&C cards. Advantech's Device Drivers features a complete I/O function library to help boost your application performance. Advantech Device Drivers for Windows 98/2000/XP works seamlessly with development tools such as Visual C++, Visual Basic, Borland C++ Builder and Borland Delphi.

Register-level Programming

Register-level programming is available for experienced programmers who find it necessary to write code directly at the level of the device register. Since register-level programming requires much effort and time, we recommend that you use the Advantech Device Drivers instead. However, if register-level programming is indispensable, you should refer to the relevant information in *Appendix C, Register Structure and Format*, or to the example codes included on the companion CD-ROM.

1.5 Device Driver Programming Roadmap

This section will provide you a roadmap to demonstrate how to build an application from scratch using Advantech Device Drivers with your favorite development tools such as Visual C++, Visual Basic, Delphi and C++ Builder. The step-by-step instructions on how to build your own applications using each development tool will be given in the *Device Drivers Manual*. Moreover, a rich set of example source code is also given for your reference.

Programming Tools

Programmers can develop application programs with their favorite development tools:

- Visual C++
- Visual Basic
- Delphi
- C++ Builder

For instructions on how to begin programming works in each development tool, Advantech offers a *Tutorial* Chapter in the *Device Drivers Manual* for your reference. Please refer to the corresponding sections in this chapter on the *Device Drivers Manual* to begin your programming efforts. You can also look at the example source code provided for each programming tool, since they can get you very well oriented.

The *Device Drivers Manual* can be found on the companion CD-ROM. Alternatively, if you have already installed the Device Drivers on your system, The *Device Drivers Manual* can be readily accessed through the Start button:

Start\Advantech Automation\Device Manager\Device Driver's Manual

The example source code could be found under the corresponding installation folder such as the default installation path:

Program Files\Advantech\ADSAP\Examples

For information about using other function groups or other development tools, please refer to the *Creating Windows 98/2000/XP Application with Device Drivers* chapter and the *Function Overview* chapter on the *Device Drivers Manual*.

Programming with Device Drivers Function Library

Advantech Device Drivers offer a rich function library that can be utilized in various application programs. This function library consists of numerous APIs that support many development tools, such as Visual C++, Visual Basic, Delphi and C++ Builder.

According to their specific functions or services, APIs can be categorized into several function groups:

- Analog Output Function Group
- Digital Input/Output Function Group
- Counter Function Group
- Port Function Group (direct I/O)
- Event Function Group

For the usage and parameters of each function, please refer to the *Function Overview* chapter in the *Device Drivers Manual*.

Troubleshooting Device Drivers Error

Driver functions will return a status code when they are called to perform a certain task for the application. When a function returns a code that is not zero, it means the function has failed to perform its designated function. To troubleshoot the Device Drivers error, you can pass the error code to `DRV_GetErrorMessage` function to return the error message. Alternatively, you can refer to the *Device Drivers Error Codes* Appendix in the *Device Drivers Manual* for a detailed listing of Error Codes, Error IDs and Error Messages.

1.6 Accessories

Advantech offers a complete set of accessory products to support the PCI-1718HDU/HGU card. These accessories include:

Wiring Cables

PCL-10120

The PCL-10120 cable is a 20-pin flat cable for PCI-1718HDU/HGU cards.

PCL-10137

The PCL-10137 shielded cable is specially designed for PCI-1718HDU/HGU cards to provide high resistance to noise. To achieve a better signal quality, the signal wires are twisted in such a way as to form a “twisted-pair cable”, reducing cross-talk and noise from other signal sources. Furthermore, its analog and digital lines are separately sheathed and shielded to neutralize EMI/EMC problems.

Wiring Boards

- **ADAM-3920** 20-pin wiring terminal for DIN-rail mounting
- **ADAM-3937** 37-pin D-type wiring terminal for DIN-rail mounting
- **PCLD-7216** 16-channel SSR I/O module carrier board
- **PCLD-780** Universal screw-terminal board
- **PCLD-782** 16-channel opto-isolated D/I board
- **PCLD-782B** 24-channel opto-isolated D/I board
- **PCLD-785** 16-channel relay output board
- **PCLD-785B** 24-channel relay output board
- **PCLD-786** 8-channel SSR I/O module carrier board
- **PCLD-788** 16-channel relay multiplexer board
- **PCLD-789D** Amplifier and multiplexer board
- **PCLD-880** Universal screw-terminal board
- **PCLD-885** 16-channel power relay output board
- **PCLD-8115** Industrial wiring terminal with CJC circuit

Installation

This chapter provides a packaged item checklist, proper instructions for unpacking and step-by-step procedures for both driver and card installation..

Sections include:

- Unpacking
- Driver Installation
- Hardware Installation
- Device Setup & Configuration

Chapter 2 Installation

2.1 Unpacking

After receiving your PCI-1718HDU/HGU package, please inspect its contents first. The package should contain the following items:

- PCI-1718HDU or PCI-1718HGU card
- Companion CD-ROM (Device Drivers included)
- User Manual

The PCI-1718 cards harbor certain electronic components vulnerable to *electrostatic discharge* (ESD). ESD can easily damage the integrated circuits and certain components if preventive measures are ignored.

Before removing the card from the antistatic plastic bag, you should take the following precautions to ward off possible ESD damage:

- Touch the metal part of your computer chassis with your hand to discharge the static electricity accumulated on your body. Alternatively, one can also use a grounding strap.
- Touch the anti-static bag to a metal part of your computer chassis before opening the bag.
- Take hold of the card only by the metal bracket when removing it out of the bag.

After taking out the card, you should first:

- Inspect the card for any possible signs of external damage (loose or damaged components, etc.). If the card is visibly damaged, please notify our service department or our local sales representative immediately. Do not install a damaged card into your system.

Also, pay extra caution to the following aspects during installation:

- Avoid physical contact with materials that could hold static electricity such as plastic, vinyl and Styrofoam.
- Whenever you handle the card, grasp it only by its edges. **DO NOT TOUCH** the exposed metal pins of the connector or the electronic components.

Note: *Keep the anti-static bag for future use. You might need the original bag to store the card if you have to remove the card from a PC or transport it elsewhere.*

2.2 Driver Installation

We recommend you install the driver before you install the PCI-1718HDU/HGU card into your system, since this will guarantee a smooth installation process.

The Advantech Device Drivers Setup program for the PCI-1718HDU/HGU card is included in the companion CD-ROM that is shipped with your DA&C card package. Please follow the steps below to install the driver software:

1. Insert the companion CD-ROM into your CD-ROM drive.
2. The Setup program will be launched automatically if you have the autoplay function enabled on your system. When the Setup Program is launched, you will see the following Setup Screen.

Note: *If the autoplay function is not enabled on your computer, use Windows Explorer or Windows Run command to execute **SETUP.EXE** on the companion CD-ROM.*



Figure 2.1: Setup Screen of Advantech Automation Software

3. Select the *Device Drivers* option.
4. Select the specific device then just follow the installation instructions step by step to complete your device driver installation and setup.

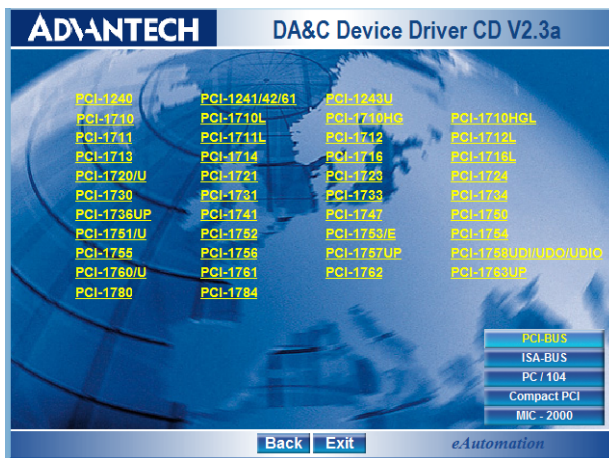

Figure 2.2: Different Options for Driver Setup

For further information on driver-related issues, an online version of the *Device Drivers Manual* is available by accessing the following path:

Start/Advantech Automation/Device Manager/Device Driver's Manual

2.3 Hardware Installation

Note: Make sure you have installed the driver before you install the card (please refer to chapter 2.2 Driver Installation)

After the Device Drivers installation is completed you can install the PCI-1718HDU/HGU card into any PCI slot on your computer. However, it is suggested that you refer to the computer's user manual or related documentation if you have any doubts. Please follow the steps below to install the card onto your system.

1. Turn off your computer and unplug the power cord and cables. TURN OFF your computer before installing or removing any components on the computer.
2. Remove the cover of your computer.
3. Remove the slot cover on the back panel of your computer.
4. Touch the metal part on the surface of your computer to neutralize the static electricity that might be on your body.
5. Insert the PCI-1718HDU/HGU card into a PCI slot. Hold the card only by its edges and carefully align it with the slot. Insert the card firmly into place. Use of excessive force must be avoided; otherwise, the card might be damaged.
6. Fasten the bracket of the PCI card on the back panel rail of the computer with screws.
7. Connect appropriate accessories (37-pin cable, wiring terminals, etc. if necessary) to the PCI card.
8. Replace the cover of your computer chassis. Re-connect the cables you removed in step 2.
9. Plug in the power cord and turn on the computer.

After your card is properly installed on your system, you can now configure your device using the *Advantech Device Manager* Program that has itself already been installed on your system during driver setup. A complete device installation procedure should include *device setup, configuration* and *testing*. The following sections will guide you through the Setup, Configuration and Testing of your device.

2.4 Device Setup & Configuration

The *Advantech Device Manager* program is a utility that allows you to set up, configure and test your device, and later stores your settings on the system registry. These settings will be used when you call the APIs of Advantech Device Drivers.

Setting Up the Device

1. To install the I/O device for your card, you must first run the *Device Installation* program (by accessing *Start/Advantech Automation/Device Manager/Advantech Device Manager*).
2. You can then view the device(s) already installed on your system (if any) on the *Installed Devices* list box. Since you have not installed any device yet, you might see a blank list such as the one below (Fig. 2-3).

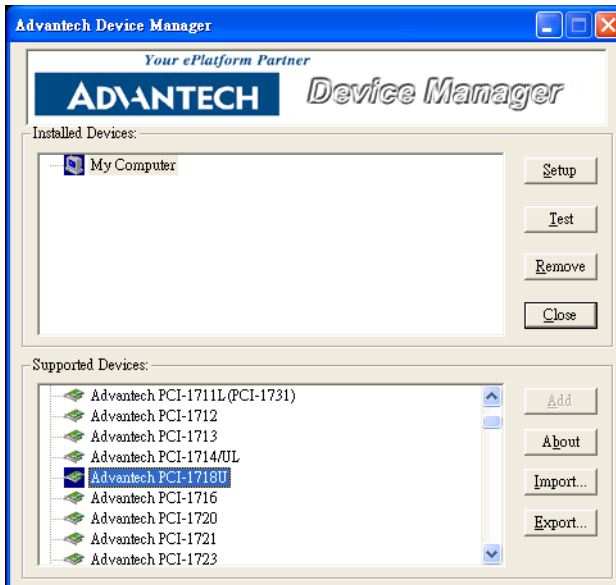

Figure 2.3: The Device Manager Dialog Box

3. Scroll down the *List of Devices* box to find the device that you wish to install, then click the *Add...* button. You will see a *Device Setting* dialog box such as the one in Fig. 2-4.

Configuring the Device

4. On the *Device Setting* dialog box (Fig. 2-4), you can configure the A/D channels configuration either as *8 Differential* or *16 Single-ended*, and specify the D/A voltage reference either as *External* or *Internal*.

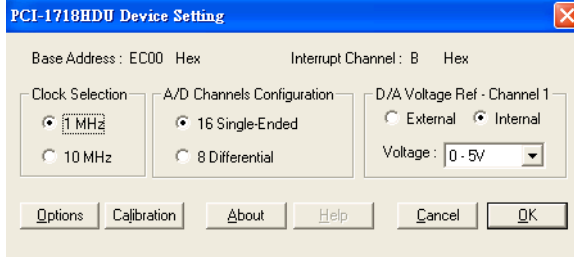

Figure 2.4: The Device Setting Dialog Box

5. After you have finished configuring the device, click OK and the *device name* will appear in the *Installed Devices* box as seen below:

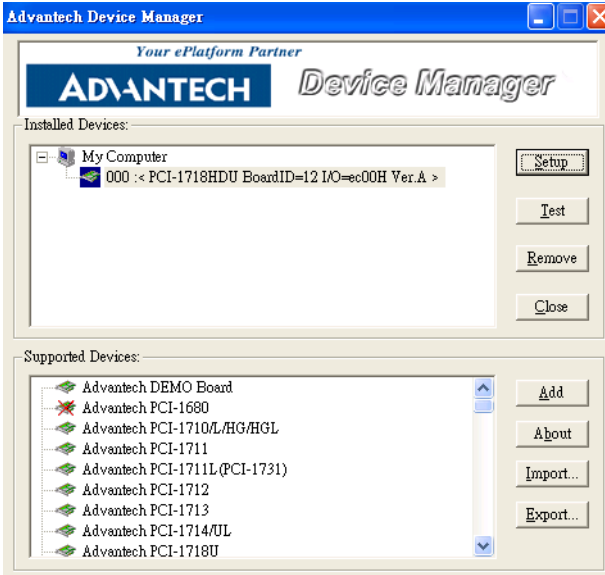

Figure 2.5: Device Name Appearing on the List of Devices Box

After your card is properly installed and configured, you can click the **Test...** button to test your hardware by using the testing utility supplied.

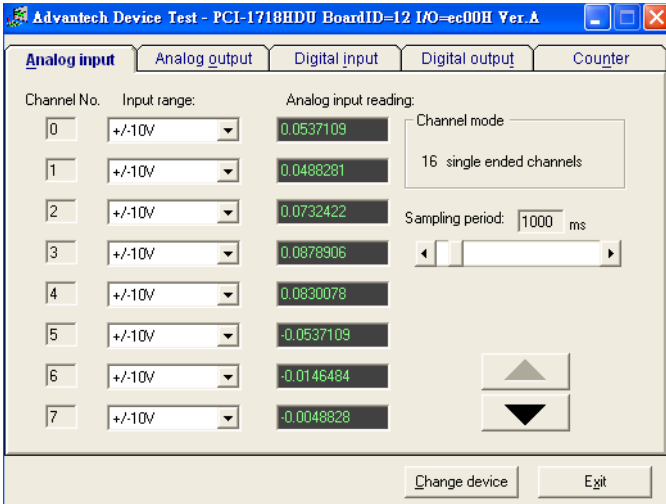

Figure 2.6: The Test Utility Dialog Box

For more detailed information, please refer to *Chapter 2* of the *Device Drivers Manual*.

You can also find rich examples on the CD-ROM to speed up your programming.

Signal Connections

This chapter provides useful information about how to connect input and output signals to the PCI-1718 cards via the I/O connector..

Sections include:

- Overview
- Switch and Jumper Settings
- Signal Connections
- Field Wiring Considerations

Chapter 3 Signal Connections

3.1 Overview

Maintaining signal connections is one of the most important factors in ensuring that your application system is sending and receiving data correctly. A good signal connection can avoid unnecessary and costly damage to your PC and other hardware devices. This chapter provides useful information about how to connect input and output signals to the PCI-1718 cards via the I/O connector.

3.2 Switch and Jumper Settings

PCI-1718 cards have two function switches and five jumper settings.

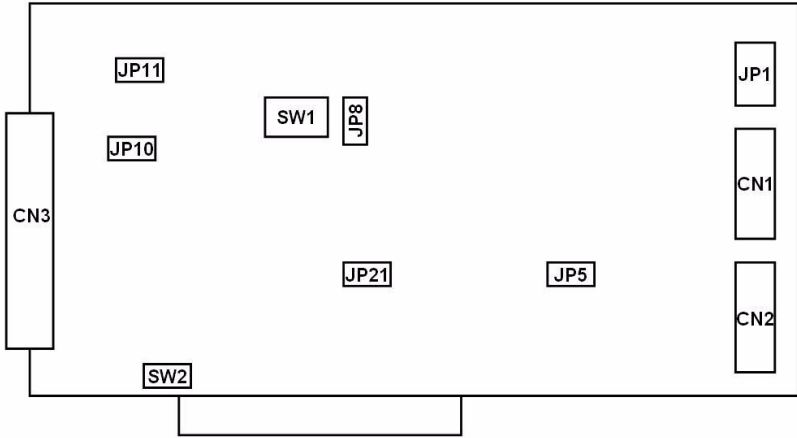

Figure 3.1: Card Connector, Jumper and Switch Locations

JP	Description	SW/CN	Description
JP1	Digital Output Connector Setting	SW1	BoardID Setting
JP5	Trigger Source & Gate Control Setting	SW2	S.E/Diff Connection Setting
JP8	Timer Clock Setting	CN1	IDE 20-pin Header 1
JP10	Internal Reference Voltage Setting	CN2	IDE 20-pin Header 2
JP11	D/A Reference Voltage Setting	CN3	DB-37 Pin Connector
JP21	Reset Protection Setting		

3.2.1 Setting the BoardID Switch (SW1)

BoardID settings are used to set a board's unique identifier when multiple identical cards are installed in the same system.

PCI-1718 cards have a built-in DIP switch (SW1), which is used to define each card's unique identifier. You can determine the unique identifier in the register as shown in Table 3.1. If there are multiple identical cards in the same chassis, the BoardID switch helps differentiate the boards by identifying each card's device number with the switch setting. The BoardID switch's unique identifier has been set to 0 at the factory.

If you need to adjust it to other numbers, set SW1 by referring to DIP switch settings below.

Table 3.1: Board ID Setting (SW1)



SW1	3	2	1	0
BoardID	ID3	ID2	ID1	ID0
0	ON	ON	ON	ON
1	ON	ON	ON	OFF
2	ON	ON	OFF	ON
3	ON	ON	OFF	OFF
4	ON	OFF	ON	ON
5	ON	OFF	ON	OFF
6	ON	OFF	OFF	ON
7	ON	OFF	OFF	OFF
8	OFF	ON	ON	ON
9	OFF	ON	ON	OFF
10	OFF	ON	OFF	ON
11	OFF	ON	OFF	OFF
12	OFF	OFF	ON	ON
13	OFF	OFF	ON	OFF
14	OFF	OFF	OFF	ON
15	OFF	OFF	OFF	OFF

Default Setting is 0

3.2.2 Channel Configuration, S/E or DIFF (SW2)

The PCI-1718 cards offer 16 single-ended or eight differential analog input channels. Slide switch SW2 changes the channels between single-ended or differential input. Slide the switch to the left-hand position, marked DIFF, for eight differential inputs (the default) or to the right-hand position, marked S/E, for 16 single-ended inputs.



Table 3.2: Summary of Switch SW2 Settings

Switch	Function description
SW2	 Differential (default)
	 Single-ended

3.2.3 D/A Reference Voltage, int./ext. (JP11)

Jumper JP11 selects reference voltage source for PCI-1718 cards' D/A converters. You can use the cards' internal reference, or supply an external reference.

Table 3.3: Summary of Jumper JP11 Settings

Jumper	Function description
JP11	 External
	 Internal (default)

When you set JP11 to INT, the D/A converter takes its reference voltage input from the card's onboard reference. Jumper JP10 selects either -5 V or -10 V onboard reference voltage. With JP11 set to INT the D/A channel has an output range of 0 to +5 V or 0 to +10 V, respectively.

When you set JP11 to EXT, the D/A converter takes its reference voltage input from pin 31 of connector CN3. You can apply any voltage between -10 V and +10 V to this pin to function as the external reference. The reference input can be either DC or AC (<100 kHz).

When you use an external reference with voltage V_{ref} you can program the D/A channel to output from 0 V to $-V_{ref}$, you can also use the D/A converter as a programmable attenuator. The attenuation factor between reference input and analog output is:

$$\text{Attenuation factor} = G / 4095$$

G is a value you write to the D/A registers between 0 and 4095. For example, if you set G to 2048, then the attenuation factor is 0.5. A sine wave of 10 V amplitude applied to the reference input will generate a sine wave of 5 V amplitude on the analog output.

3.2.4 Internal Voltage Reference, -10 V or -5 V (JP10)

If you use an internal reference voltage (set with JP10), the PCI-1718 cards provide a choice between -5 V or -10 V DC internal reference voltage sources.



<i>Table 3.4: Summary of Jumper JP10 Settings</i>		
Jumper	Function description	
JP10		5 V (default)
		10 V

Table 3-1: Summary of jumper JP10 settings

3.2.5 Timer Clock Selection (JP8)



PCI-1718's JP8 controls the input clock frequency for the 8254 programmable clock/timer. You have two choices: 10 or 1 MHz. This lets you generate pacer output frequencies from 2.5 MHz to 0.00023 Hz (71 minutes/pulse).

The following equation gives the pacer rate:

$$\text{Pacer rate} = \text{Fclk} / (\text{Div1} * \text{Div2})$$

Fclk is 1 MHz or 10 MHz, as set by jumper JP8. Div 1 and Div2 are the dividers set in counter 1 and counter 2 in the 8254.





Table 3.5: Summary of Jumper JP8 Settings

Jumper	Function description	
JP8		1 MHz (default)
		10 MHz

3.2.6 Ext. trigger and Counter Gate 0 Control (JP5)

Jumper 5 determines the source of A/D external trigger signal (Lower) and gate control for counter 0 on 8254 timer/counter.(Upper).

Table 3.6: Summary of Jumper Settings









Jumper	Function description
JP5 (Upper)	 G0 (default)
	 DI2
JP5 (Lower)	 Ext. (default)
	 DI0

3.2.7 Digital Output, 20-pin or 37-pin Connector (JP1)

The PCI-1718 cards' JP1 switch digital output channels 0 to 3 between the card's 20-pin connector and 37-pin connector. If you set the jumpers to the left (D) side, the digital output signals will come out on connector CN1 (20-pin). If you set the jumpers to the right (S) side, the output signals will come out on connector CN3 (37-pin).

These four digital output signals select the analog input channel when you use a multiplexer/amplifier daughter board. Daughter boards with a DB-37 connector, such as the PCLD-789D, read the digital output signals from the DB-37 connector (CN3). With other daughter boards you will need to connect an external 20-pin flat cable from CN1 to the daughter board.

Table 3.7: Summary of Jumper Settings

Jumper	Function Description	
JP1 (first)		S0
		D0 (default)
JP1 (second)		S1
		D1 (default)
JP1 (third)		S2
		D2 (default)
JP1 (fourth)		S3
		D3 (default)



3.2.8 Setting the Time to Reset Digital Outputs

Some users will want the capability of clearing each digital output when the system (or PC) issues a reset signal on the PCI bus. Other users will want to clear their signal outputs only as part of system power-on.

PCI-1718 cards satisfy both these needs with jumper JP21. Depending on the application, this capability may allow digital outputs to be “OFF” without requiring a complete shutdown of processes controlled by the card.

Complete loss of power to the chip clears the chip memory. Thus, no matter how JP21 is set, if the power to the PCI-1718 card is disconnected, the digital output channel’s initial power-on state will be “OFF”.

Table 3.8: JP21 Jumper Settings

Jumper	Function description
JP21	 Keep last status after hot reset.
	 Reset status after hot reset (default)

3.3 Signal Connections

Pin Assignment

Figure 3-2 shows the pin assignments for the 37-pin I/O connector on the PCI-1718HDU/HGU.

CN1			CN2		
D/O 0	1	2 D/O 1	D/I 0	1	2 D/I 1
D/O 2	3	4 D/O 3	D/I 2	3	4 D/I 3
D/O 4	5	6 D/O 5	D/I 4	5	6 D/I 5
D/O 6	7	8 D/O 7	D/I 6	7	8 D/I 7
D/O 8	9	10 D/O 9	D/I 8	9	10 D/I 9
D/O 10	11	12 D/O 11	D/I 10	11	12 D/I 11
D/O 12	13	14 D/O 13	D/I 12	13	14 D/I 13
D/O 14	15	16 D/O 15	D/I 14	15	16 D/I 15
D.GND	17	18 D.GND	D.GND	17	18 D.GND
+5 V	19	20 +12 V	+5 V	19	20 +12 V

CN3 (Single ended)

A/D S0	1	20 A/D S8
A/D S1	2	21 A/D S9
A/D S2	3	22 A/D S10
A/D S3	4	23 A/D S11
A/D S4	5	24 A/D S12
A/D S5	6	25 A/D S13
A/D S6	7	26 A/D S14
A/D S7	8	27 A/D S15
A.GND	9	28 A.GND
A.GND	10	29 A.GND
VREF	11	30 DA0.OUT
S0*	12	31 DA0.VREF
+12 V	13	32 S1*
S2*	14	33 S3*
D.GND	15	34 D.GND
NC	16	35 EXT.TRIG
Counter 0 CLK	17	36 Counter 0 GATE
Counter 0 OUT	18	37 PACER
+5 V	19	

CN3 (Differential)

A/D H0	1	20 A/D L0
A/D H1	2	21 A/D L1
A/D H2	3	22 A/D L2
A/D H3	4	23 A/D L3
A/D H4	5	24 A/D L4
A/D H5	6	25 A/D L5
A/D H6	7	26 A/D L6
A/D H7	8	27 A/D L7
A.GND	9	28 A.GND
A.GND	10	29 A.GND
VREF	11	30 DA0.OUT
S0*	12	31 DA0.VREF
+12 V	13	32 S1*
S2*	14	33 S3*
D.GND	15	34 D.GND
NC	16	35 EXT.TRIG
Counter 0 CLK	17	36 Counter 0 GATE
Counter 0 OUT	18	37 PACER
+5 V	19	

Figure 3.2: I/O Connector Pin Assignments for the PCI-1718 Series

Note: S0/S1 is NC, and S2/S3 is AGND for PCI-1718HGU

3.3.1 I/O Connector Signal Description

Table 3.9: I/O Connector Signal Descriptions

Signal Name	Reference	Direction	Description
A/D S <0..15>	A.GND	Input	Analog input (single-ended), channels 0 through 15.
A/D H <0..7>	A.GND	Input	Analog input high (differential), channels 0 through 7.
A/D L <0..7>	A.GND	Input	Analog input low (differential), channels 0 through 7.
D/A	A.GND	Output	Analog output
AGND	-	-	Analog Ground. The two ground references (A.GND and D.GND) are connected together on the PCI-1718HDU/HGU card.
D/O	D.GND	Output	Digital output, channels 0 through 15.
D/I	D.GND	Input	Digital input, channels 0 through 15.
CLK	D.GND	Input	Clock input for the 8254.
GATE	D.GND	Input	Gate input for the 8254.
OUT	D.GND	Output	Signal output for the 8254.
VREF	D.GND	Output	Voltage reference.
REFIN	D.GND	Input	External voltage reference input.
S1-S4	D.GND	Output	Daughterboard channel select.
DGND	-	-	Digital Ground. The two ground references (A.GND and D.GND) are connected together on the PCI-1718HDU/HGU card.
+12V	D.GND	Output	+12 VDC Source (from PCI bus directly with FUSE protection).
+5V	D.GND	Output	+5 VDC Source (from PCI bus directly with FUSE protection).
NC	-	-	No connection.

3.3.2 Analog Input Connections

PCI-1718HDU/HGU supports either 16 single-ended or 8 differential analog inputs. Switch SW2 selects the input channel configuration.

Single-ended Channel Connections

Single-ended connections use only one signal wire per channel. The voltage on the line references to the common ground on the card. A signal source without a local ground is called a "floating" source. It is fairly simple to connect a single ended channel to a floating signal source. A standard wiring diagram looks like this:

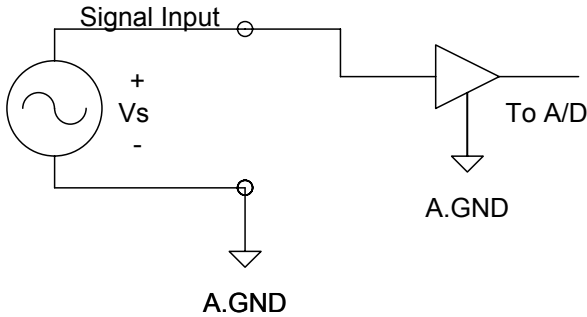

Differential Channel Connections

Differential input connections use two signal wires per channel. The card measures only the voltage difference between these two wires, the HI wire and the LOW wire. If the signal source has no connection to ground, it is called a "floating" source. A connection must exist between LOW and ground to define a common reference point for floating signal sources. To measure a floating sources connect the input channels as shown below:

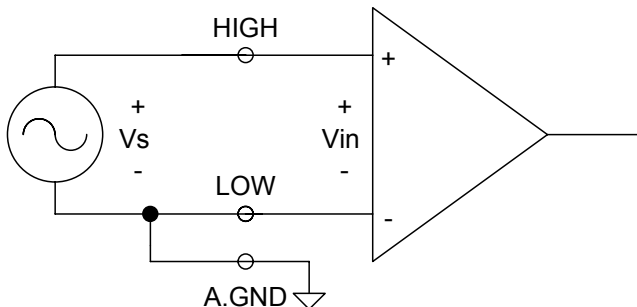

If the signal source has one side connected to a local ground, the signal source ground and the PCI-1718HDU/HGU ground will not be at exactly the same voltage, as they are connected through the ground return of the equipment and building wiring. The difference between the ground voltages forms a common-mode voltage.

To avoid the ground loop noise effect caused by common-mode voltages, connect the signal ground to the LOW input. Do not connect the LOW input to the PCI-1718HDU/HGU ground directly. In some cases you may also need a wire connection between the PCI-1718HDU/HGU ground and the signal source ground for better grounding. The following two diagrams show correct and incorrect connections for a differential input with local ground:

Correct Connection

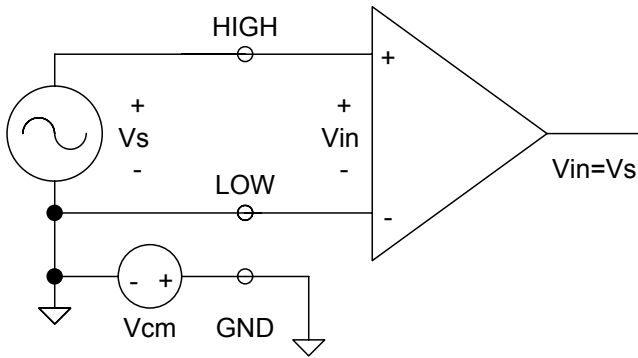

Incorrect Connection

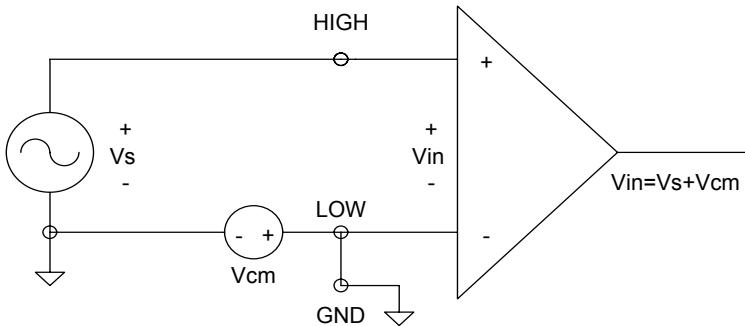

Expanding Analog Inputs

You can expand any or all of the PCI-1718HDU/HGU's A/D input channels using multiplexing daughterboards. Daughterboards without D-type connectors require the PCLD-774 Analog Expansion Board.

The PCLD-789(D) Amplifier and Multiplexer multiplexes 16 differential inputs to one A/D input channel. You can cascade up to eight PCLD-789(D)s to the PCI-1718HDU/HGU for a total of 128 channels. See the PCLD-789(D) user's manual for complete operating instructions.

The PCLD-774 Analog Expansion Board accommodates multiple external signal-conditioning daughter boards, such as PCLD-779 and PCLD-789(D). It features five sets of on-board 20-pin header connectors. A special star-type architecture lets you cascade multiple signal-conditioning boards without the signal-attenuation and current-loading problems of normal cascading.

The PCLD-8115 Screw Terminal Board makes wiring connections easy. It provides 20-pin flat cable and DB-37 cable connectors. It also includes CJC (Cold Junction Compensation) circuits.

Special circuit pads on the PCLD-8115 accommodate passive signal conditioning components. You can easily implement a low-pass filter, attenuator or current shunt by adding resistors and capacitors.

Analog Output Connection

The PCI-1718H DU/HGU provides one D/A output channel. You can use the internal precision -5 V or -10 V reference to generate 0 to +5 V or 0 to +10 V D/A output. Use an external reference for other D/A output ranges. The maximum reference input voltage is ± 10 V and maximum output scaling is ± 10 V. Loading current for D/A outputs should not exceed 5 mA.

Connector CN3 provides D/A signals. Important D/A signal connections such as input reference, D/A outputs and analog ground appear below:

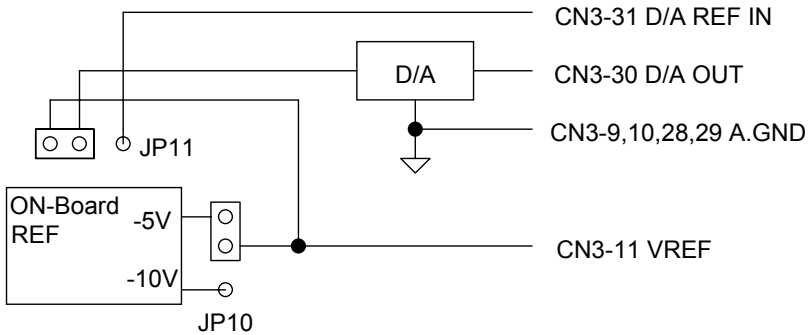
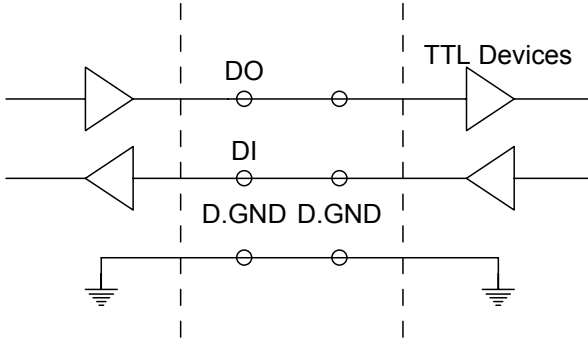

Figure 3.3: Analog Output Connections

3.3.3 Digital Signal Connections

The PCI-1718HDU/HGU has 16 digital input and 16 digital output channels. The digital I/O levels are TTL compatible. The following figure shows connections to exchange digital signals with other TTL devices:



To receive an OPEN/SHORT signal from a switch or relay, add a pull-up resistor to ensure that the input is held at a high level when the contacts are open. See the figure below:

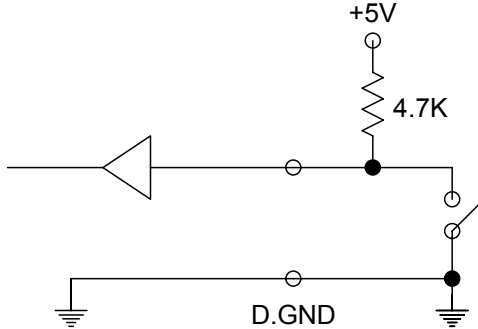

3.4 Field Wiring Considerations

When you use PCI-1718 cards to acquire data from outside, noises in the environment might significantly affect the accuracy of your measurements if due cautions are not taken. The following measures will be helpful to reduce possible interference running signal wires between signal sources and the PCI-1718 card.

- The signal cables must be kept away from strong electromagnetic sources such as power lines, large electric motors, circuit breakers or welding machines, since they may cause strong electromagnetic interference. Keep the analog signal cables away from any video monitor, since it can significantly affect a data acquisition system.
- If the cable travels through an area with significant electromagnetic interference, you should adopt individually shielded, twisted-pair wires as the analog input cable. This type of cable has its signal wires twisted together and shielded with a metal mesh. The metal mesh should only be connected to one point at the signal source ground.
- Avoid running the signal cables through any conduit that might have power lines in it.
- If you have to place your signal cable parallel to a power line that has a high voltage or high current running through it, try to keep a safe distance between them. Alternatively, you can place the signal cable at a right angle to the power line to minimize the undesirable effect.
- The signals transmitted on the cable will be directly affected by the quality of the cable. In order to ensure better signal quality, we recommend that you use the PCL-10137 shielded cable.

Programming Guide

This chapter provides useful information about how to do register level programming for PCI-1718 cards.

Sections include:

- Overview
- Programming with the Driver
- Register Programming
- Programming with LabVIEW and ActiveDAQ

Chapter 4 Programming Guide

4.1 Overview

The PCI-1718 cards are delivered with an easy-to-use 32-bit Device Driver for user programming under the Windows 98/2000/XP operating systems.

At the Windows driver level, PCI-1718 cards are fully compatible with the PCL-818 series so you can easily use older applications of the PCL-818 series with PCI-1718 cards. We also advise users to program the PCI-1718 cards using the 32-bit Device Drivers provided by Advantech to avoid the complexity of low-level registry programming.

4.2 Programming with the Driver

Your program can perform A/D by writing all the I/O port instructions directly, or you can take advantage of the PCI-1718 driver. We suggest that you make use of the driver functions in your program. This will make your programming job easier and improve your program's performance.

See the Software Driver User's Manual for more information.

Start/Advantech Automation/Device Manager/Device Driver's Manual

4.3 Register Programming.

The most important consideration in programming the PCI-1718 cards at register level is to understand the function of the card's registers and the process of programming. The information in the following sections is provided only for users who would like to do their own low-level programming.

Without the driver you would do the following: perform software trigger, pacer trigger with interrupt, pacer trigger with interrupt and FIFO, and program a controlled data transfer.

4.3.1 Software Trigger and Polling

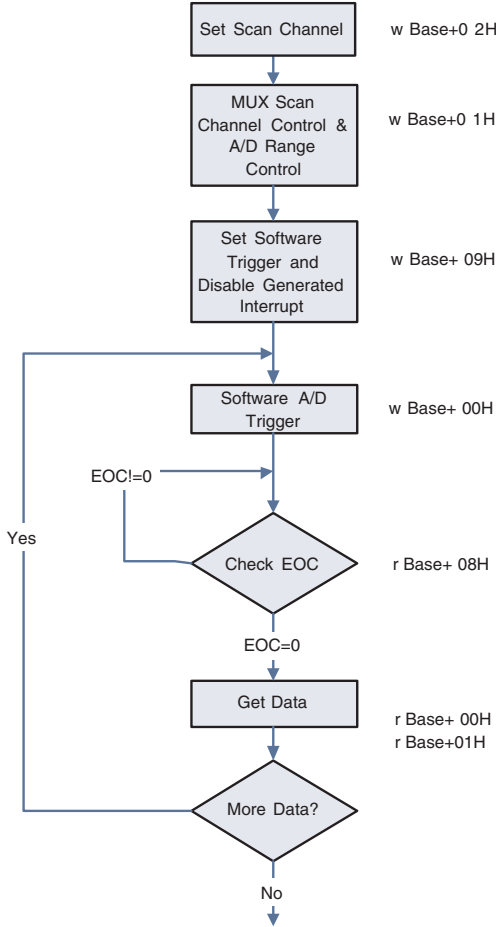

1. Set the input range for each A/D channel
2. Set the input channel by specifying the MUX scan range
3. Trigger the A/D conversion by writing to the A/D low byte register (BASE+0) with any value.
4. Check for the end of the conversion by reading the A/D status register (BASE+8) EOC bit.
5. Read data from the A/D converter by reading the A/D data register (BASE+0 and BASE+1)
6. Convert the binary A/D data to an integer.

Example Code:

```
/******This code supports TurboC 3.0 or later versions*****/  
#include <stdio.h>  
#include <DOS.h>  
#define AD_NO 4096; // Number of Samples  
int base_addr;  
void main(void)  
{  
    int ad_lb,ad_hb; //Declaration  
    int i;  
    int eoc;  
    /****** Access your base address *****/  
        //Add your code here  
    /******  
    outportb(base_addr+0x02,0x00); //Set Channel 0  
    outportb(base_addr+0x01,0x00); //Set A/D range  
    outportb(base_addr+0x02,0x11); //Set Channel 1  
    outportb(base_addr+0x01,0x01); //Set A/D range  
    outportb(base_addr+0x02,0x10); //Scan Channel 0-1  
    outportb(base_addr+0x09,0x00);  
  
    while(i<AD_NO){  
        outportb(base_addr+0x00,0); //Software Trigger  
        do {eoc=inportb(base_addr+0x08);  
            eoc=eoc&0x01; //Get EOC}  
        while(eoc!=0); //Check EOC  
        ad_lb=inportb(base_addr+0x00); // A/D LowByte  
        ad_hb=inportb(base_addr+0x01); // A/D HighByte  
        i++;  
    }  
}
```

4.3.2 Pacer Trigger Mode with Interrupt

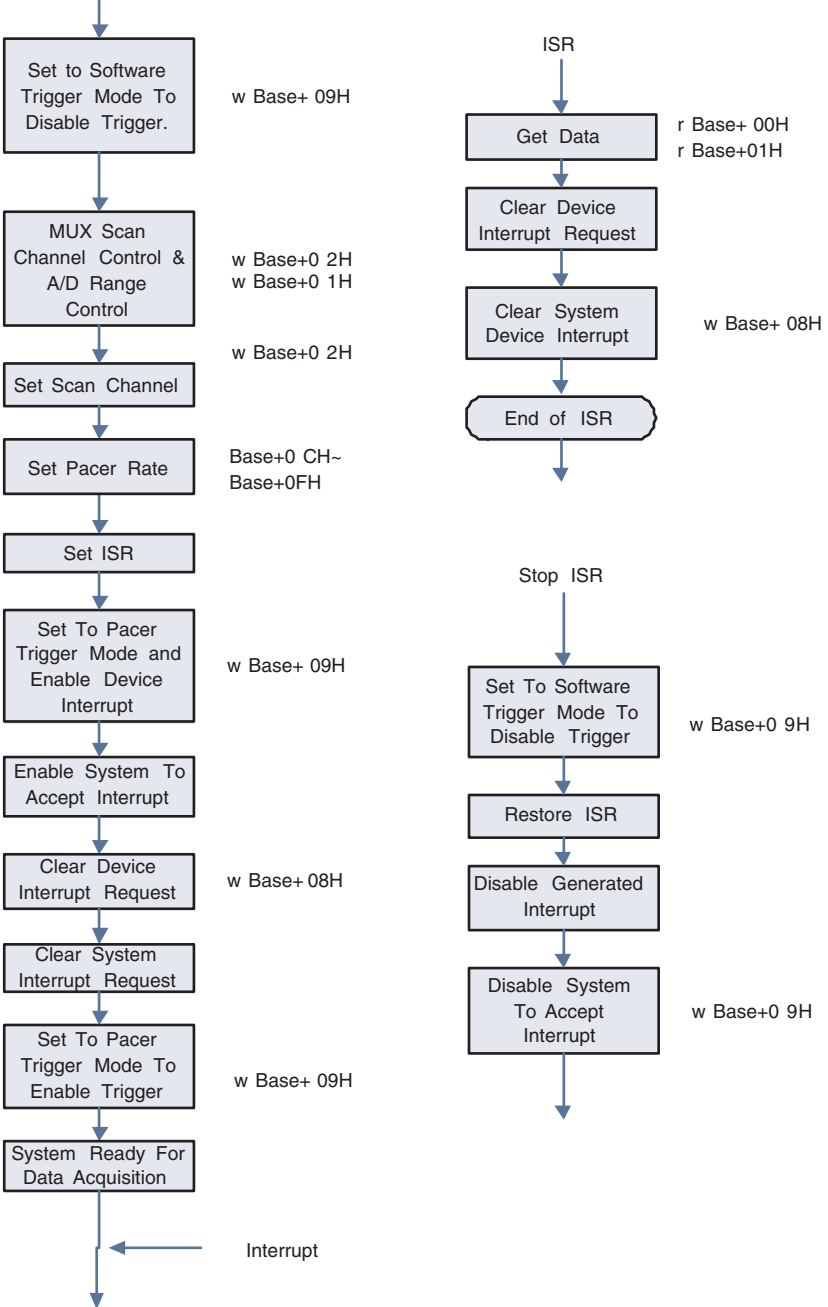

1. Set the input range for each A/D channel
2. Set the input channel by specifying the MUX scan range
3. Set pacer rate and interrupt service routine (ISR)
4. Enable device to generate interrupts and system to accept interrupts
5. Trigger the A/D conversion by writing “1” to the A/D control register (BASE+9)
6. Interrupts generate by the device when the A/D conversion is completed.
7. Read data from the A/D converter by reading the A/D data register (BASE+0 and BASE+1)
8. Convert the binary A/D data to an integer.

Example Code:

```

/*****This code supports TurboC 3.0 or later versions*****/
#include <stdio.h>
#include <DOS.h>
void interrupt isr(void);

#define AD_NO 4096; //Number of Samples
int iflag;
int base_addr;

void main(void)
{
    int ad_lb,ad_hb; //Declaration
    int i=1;
    /***** Access your base address *****/
        Add you code here
    /*****/
    outportb(base_addr+9,0x00); //Set Software Trigger and Disable INT.
    outportb(base_addr+2,0x00); //Mux Scan Channel Control
    outportb(base_addr+1,0x00); //A/D Range Control

```

```

    /***** Set Pacer *****/
    outputb(base_addr+0x0f,0x7E); //Pacer=1M/clk1/clk2
    outputb(base_addr+0x0d,0x0A); //clk1
    outputb(base_addr+0x0d,0x00); //10=0x0A ; 100=0x64 ;
1000=0x3E8
    outputb(base_addr+0x0f,0xBE);
    outputb(base_addr+0x0e,0x0A); //clk2
    outputb(base_addr+0x0e,0x00);
    /***** Pacer=1M/10/10=10k *****/

    /***** Set ISR *****/
    Add you code here
    /*****/

    /***** Set Interrupt *****/
    Add you code here
    /*****/

    outputb(base_addr+8,0); //Clear Interrupt
    outputb(base_addr+9,0xf3); //Set Pacer Trigger and Enable INT
    /***** Ready for Data Acquisition *****/
    while(i<AD_NO)
    {
        while(iflag==0) {;}//Wait for Interrupt
        ad_lb=inportb(base_addr+0); //Get A/D LowByte
        ad_hb=inprtb(base_addr+1);//Get A/D HighByte
        i++
    }
    /***** END *****/
}

```

```
void interrupt isr(void)
{
    disable();
    /**** Add code on here ***/
    iflag = 1; //Interrupt Flag
    outportb(base_addr+0x08,0);// Clear Interrupt
    /*****/
    outportb(0x20,0x20);
    outportb(0xA0,0x20);
    enable();
}
```

4.3.3 Pacer Trigger Mode with Interrupt and FIFO

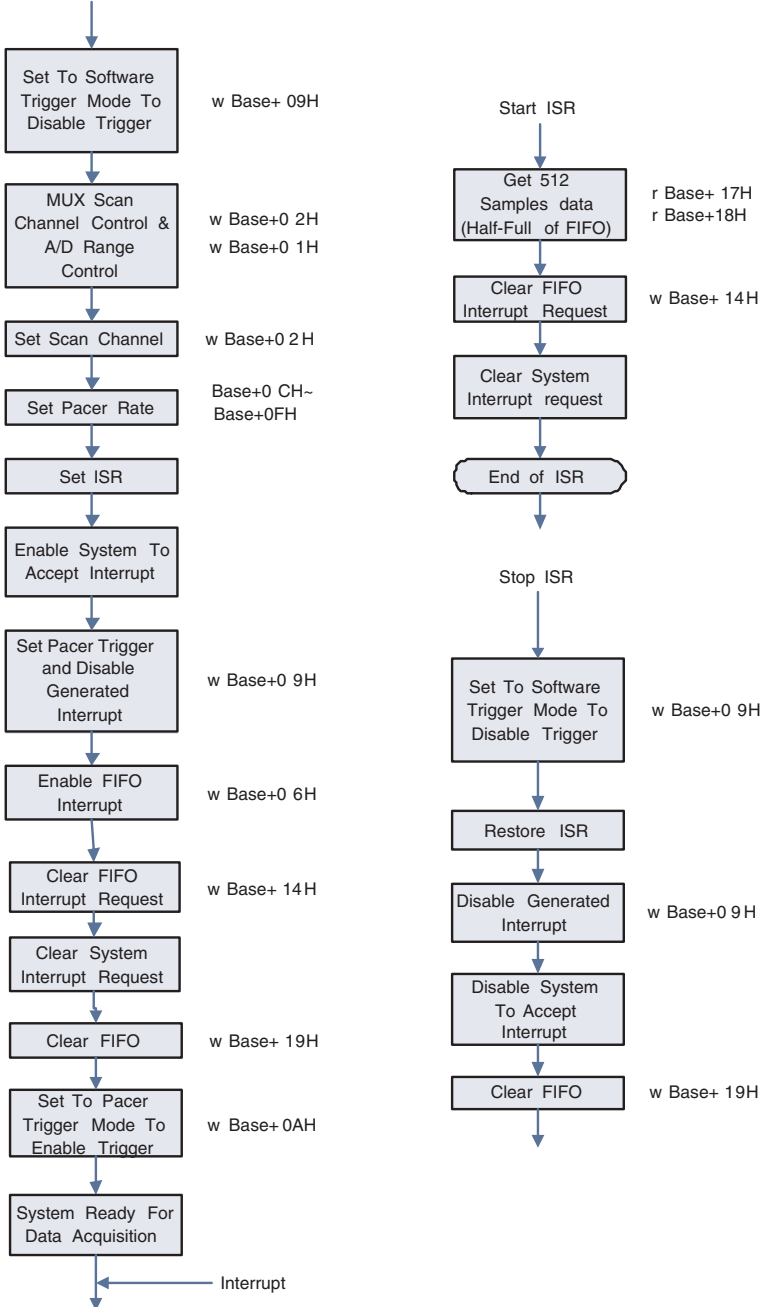

1. Set the input range for each A/D channel
2. Set the input channel by specifying the MUX scan range
3. Set pacer rate and interrupt service routine (ISR)
4. Enable FIFO to generate interrupts and system to accept interrupts
5. Trigger the A/D conversion by writing "1" to the A/D control register (BASE+9)
6. Interrupts generate by FIFO when FIFO is half-full.
7. Read data from the A/D converter by reading the FIFO A/D data register (BASE+17 and BASE+18)
8. Convert the binary A/D data to an integer.

Example Code:

```

/*****This code supports TurboC 3.0 or later versions*****/
#include <stdio.h>
#include <DOS.h>

void interrupt isr(void);
#define AD_NO 4096;
int iflag;
int base_addr;
void main(void)
{
    int ad_lb,ad_hb;
    int i=1;
    int k=0; //FIFO index
    /***** Access your base address *****/
        Add you code here
    /*****/
    // Set Software Trigger and Disable Nor INT
    outportb(base_addr+0x09,0x00);

```

```

    outportb(base_addr+0x02,0x00); //MUX Scan Channel Control
    outportb(base_addr+0x01,0x03); //Channel 1 Gain Setting
    outportb(base_addr+0x02,0x11); // MUX Scan Channel Control
    outportb(base_addr+0x01,0x08); // Channel 2 Gain Setting
    outportb(base_addr+0x02,0x10); //Scan Channel 0-1
    /***** Set Pacer *****/
    outportb(base_addr+0x0f,0x7e);
    outportb(base_addr+0x0d,10); //Divide By 1
    outportb(base_addr+0x0d,0);
    outportb(base_addr+0x0f,0xbe);
    outportb(base_addr+0x0e,20); //Divide By 2
    outportb(base_addr+0x0e,0);
    /***** Set ISR *****/
    Add your code here
    /*****/
    /***** Set System Interrupt *****/
    Add your code here
    /*****/

    outportb(base_addr+0x09,0x00); // Disable Nor INT and Set Pacer
Trigger
    outportb(base_addr+0x06,0x01); // Enable FIFO INT
    outportb(base_addr+0x14,0x00); // Clear FIFO Interrupt

    /***** Clear System Interrupt*****/
    Add you code here
    /*****/

    outportb(base_addr+0x19,0x00); // Clear FIFO
    outportb(base_addr+10,0); // Enable Pacer
    while(i<=AD_NO)
    {

```

```

while(iflag==0) {;}
/***** FIFO HALF Interrupt and Get Data *****/
for(k=0;k<512;k++)
{
    iflag=0;
    ad_lb=inportb(base_addr+0x17);
    ad_hb=inportb(base_addr+0x18);
/***** Save to Memory *****/
    Add your code here
/*****/

    i++;
}
/*****/
}

}

void interrupt isr(void)
{
    disable();
    iflag = 1;
/***** Add your code here *****/
    outportb(base_addr+0x14,0); // Clear FIFO Interrupt
/*****/
    outportb(0x20,0x20);
    outportb(0xA0,0x20);
    enable();
}

```

4.4 Programming with LabVIEW and ActiveDAQ

Advantech offers not only a rich set of DLL drivers, but also third-party driver support and application software to help fully exploit the functions of your PCI-1718 cards. For more detailed information for these applications, please refer to:

LabView

Start\Advantech Automation\LabVIEW\LabVIEW Driver's Manual

(To install Labview driver, please access: \CDROM\LabVIEW)

ActiveDAQ

Start\Advantech Automation\ ActiveDAQ \ ActiveDAQ Driver's Manual

(To install ActiveDAQ, please access: \CDROM\ActiveDAQ)

APPENDIX
A

Specifications

Appendix A Specifications

A.1 Analog Input

Channels	16 single-ended or 8 differential or combination					
Resolution	12-bit					
FIFO Size	1K samples					
Max. Sampling Rate	100 kS/s					
Input range and Gain List for PCI-1718HDU	Gain	0.5	1	2	4	8
	Unipolar	N/A	0~10	0~5	0~2.5	0~1.25
	Bipolar	±10	±5	±2.5	±1.25	±0.625
	Bandwidth	400 khz	400 kHz	400 kHz	350 kHz	300 kHz
	Gain error (% FSR)	0.01	0.01	0.04 (1LSB)	0.07 (3LSB)	0.1 (4LSB)
Input range and Gain List for PCI-1718HGU	Gain	0.5	1	10	100	1000
	Unipolar	N/A	0~10	0~0.1	0~0.01	0~0.001
	Bipolar	±10	±5	+/-0.5	+/-0.05	+/-0.005
	Bandwidth	400 Khz	400 kHz	80 kHz	10 kHz	1 kHz
	Gain error (% FSR)	0.01	0.01	0.04 (1LSB)	0.07 (1LSB)	0.1 (1LSB)
PCI-1718HDU Accuracy	DC	DNLE: ±1LSB				
		INLE: ±1LSB				
		Offset error: Adjustable to 0				
	AC	THD: -80 dB				
ENOB: 11 bits						
Zero Drift (μV/°C)	Range		0~10	0~5	0~2.5	0~1.25
			480	240	120	60
	Range	±10	±5	±2.5	±1.25	±0.625
		160	80	40	20	10
Gain Drift (PPM/°C)	40					

Common Mode Voltage	±11 V max. (operational)	
Max. Input Voltage	±15 V	
Input Protect	30 Vp-p	
Input Impedance	100 M /10pF(Off); 100 M /100pF(On)	
Trigger Mode	Software, on-board Programmable Pacer or External	
External TTL Trigger Input	Low	0.8 V max.
	High	2.0 V min.

A.2 Analog Output

Channels	1	
Resolution	12-bit	
Max. Transfer Rate	100 kS/s	
Output Range (Internal & External Reference)	Using Internal Reference	0~+5V,0~+10 V
	Using External Reference	0 ~ x V @ x V (-10 =< x =< 10)
Accuracy	INLE	±1LSB
	DNLE	±1LSB (monotonic)
	Offset error	Adjustable to ±1 LSB
	Gain error	Adjustable to ±1 LSB
Dynamic Performance	Slew Rate	10 V / μs
	Settling Time	2 μs to 0.01% of FSR
Driving Capability	±10mA	
Output Impedance	0.1 max.	

A.3 Digital Input

Input Channels	16	
Input Voltage	Low	0.4V max.
	High	2.4 V min.
Input Load	Low	0.4 V max.@ -0.2mA
	High	2.7 V min.@20 μ A

A.4 Digital Output

Output Channels	16	
Output Voltage	Low	0.4 V max.@ +8.0mA (sink)
	High	2.4 V min.@ -0.4mA(source)

A.5 Counter/Timer

Counter chip	82C54 or equivalent	
Channels	3 channels, 2 channels are permanently configured as programmable pacers; 1 channel is free for user application	
Resolution	16-bit	
Compatibility	TTL level	
Base Clock	Channel 1: 10 MHz Channel 2: Takes input from output of channel 1 Channel 0: Internal 100 kHz or external clock (10 MHz max.) selected by software	
Max. Input Frequency	10 MHz	
Clock Input	Low	0.8 V max.
	High	2.0 V min.
Gate Input	Low	0.8 V max.
	High	2.0 V min.
Counter Output	Low	0.5 V max. @+24 mA
	High	2.4 V min. @-15 mA

A.6 General

I/O Connector Type	37-pin DSUB female for Analog One 20-pin Box Header for DI One 20-pin Box Header for DO	
Dimensions	175 x 100 mm (6.9" x 3.9")	
Power Consumption	Typical	+5 V @ 850 mA
	Max.	+5 V @ 1 A
Temperature	Operating	0~60° C (32~158° F) (refer to IEC 68-2-1,2)
	Storage	-20~ 70° C (-4~158° F)
Relative Humidity	Operating	5~85%RH non-condensing (refer to IEC 68-1,-2,-3)
	Storage	5~95%RH non-condensing (refer to IEC 68-1,-2,-3)
Certifications	CE certified	

APPENDIX

B

Block Diagrams

Appendix B Block Diagrams

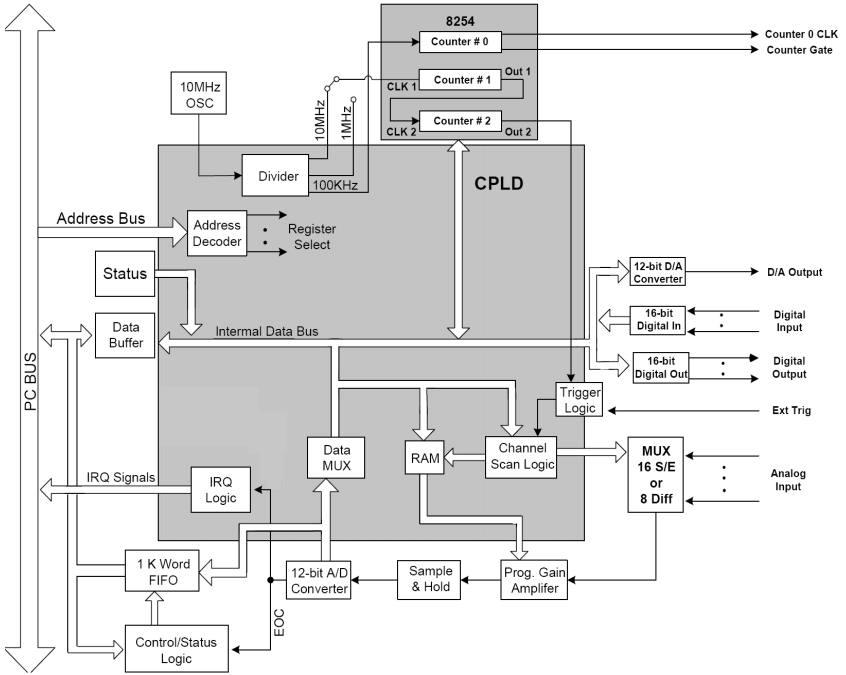

APPENDIX
C

**Register Structure &
Format**

Appendix C Register Structure & Format

C.1 Overview

PCI-1718 cards are delivered with an easy-to-use 32-bit Device Drivers for user programming under the Windows 98/2000/XP operating systems. We advise users to program the PCI-1718 cards using the 32-bit Device Drivers provided by Advantech to avoid the complexity of low-level registry programming.

The most important consideration in programming the PCI-1718 cards at the register level is to understand the function of the cards' registers. The information in the following sections is provided only for users who would like to do their own low-level programming.

To get the DOS example programs, please access:
`\CDROM\DOS\PCI\1718\`

C.2 I/O Port Address Map

PCI-1718 cards require 32 consecutive addresses in the PC's I/O space. The address of each register is specified as an offset from the card's base address. For example, `BASE+0` is the card's base address and `BASE+7` is the base address plus seven bytes.

Table C.1 shows the function of each register of PCI-1718 or driver, and its address relative to the card's base address.

Table C.1: PCI-1718HDU/HGU Register Format (Part 1)

Base Addr. +HEX		7	6	5	4	3	2	1	0
00H	R	A/D low byte data and channels							
		AD3	AD2	AD1	AD0	C3	C2	C1	C0
	W	Software A/D trigger							
01H	R	A/D high byte data and channels							
		AD11	AD10	AD9	AD8	AD7	AD6	AD5	AD4
	W	A/D range control							
02H	R	MUX scan channel status							
						CC3	CC2	CC1	CC0
	W	MUX scan channel control							
03H	R	Digital Input (low byte)							
		DI7	DI6	DI5	DI4	DI3	DI2	DI1	DI0
	W	Digital Output (low byte)							
04H	R	N/A							
	W	D/A output data							
05H	R	N/A							
	W	D/A output data							
06H	R	N/A							
	W	AD resolution & FIFO interrupt control							
07H	R	N/A							
	W	N/A							
07H	R	N/A							
	W	N/A							
07H	R	N/A							
	W	N/A							
07H	R	N/A							
	W	N/A							

Table C.2: PCI-1718H DU/HGU Register Format (Part 2)

Base Addr. +HEX		7	6	5	4	3	2	1	0
08H	R	A/D Status							
		EOC	U/B	MUX	INT	CN3	CN2	CN1	CN0
	W	Clear interrupt request							
09H	R	A/D Control							
		INTE	I2	I1	I0		DMAE	ST1	ST0
	W	A/D Control							
		INTE						ST1	ST0
0AH	R	N/A							
	W	Timer/Counter Control							
								TC1	TC0
0BH	R	Digital Input (high byte)							
		DI15	DI14	DI13	DI12	DI11	DI10	DI9	DI8
	W	Digital Output (high byte)							
		DO15	DO14	DO13	DO12	DO11	DO10	DO9	DO8
0CH	R	Counter 0							
	W	Counter 0							
0DH	R	Counter 1							
	W	Counter 1							
0EH	R	Counter 2							
	W	Counter 2							
0FH	R	N/A							
	W	Counter Control							

Table C.3: PCI-1718HDU/HGU Register Format (Part 3)

Base Addr. +HEX		7	6	5	4	3	2	1	0
14H	R	BoardID							
						ID3	ID2	ID1	ID0
	W	Clear FIFO Interrupt Request							
17H	R	A/D data and channels from FIFO							
		AD3	AD2	AD1	AD0	C3	C2	C1	C0
	W	N/A							
18H	R	A/D data and channels from FIFO							
		AD11	AD10	AD9	AD8	AD7	AD6	AD5	AD4
	W	N/A							
19H	R	FIFO status							
	W	FIFO clear							
							FF	HF	EF

C.3 A/D Data and Channels — BASE+00H~01H

Table C.4: Register for A/D Data and Channels

Read	A/D data and channels							
Bit #	7	6	5	4	3	2	1	0
BASE + 00H	AD3	AD2	AD1	AD0	C3	C2	C1	C0
BASE + 01H	AD11	AD10	AD9	AD8	AD7	AD6	AD5	AD4

- AD11 ~ AD0 Analog to digital data
- AD0 The least significant bit (LSB) of the A/D data
- AD11 The most significant bit (MSB)
- C3 ~ C0 A/D channel number from which the data is derived
- C0 The least significant bit (LSB) of the channels
- C3 The most significant bit (MSB)

C.4 Software A/D Trigger — BASE+00H

You can trigger an A/D conversion from software, the card's onboard pacer or an external pulse. If you select software triggering, a write to the register BASE+00H with any value will trigger an A/D conversion.

Bits 1 and 0 of register BASE+09H select the trigger source. See page 67 for BASE+09H register layout and programming information.

Table C.5: Register for Software A/D Trigger

Write	Software A/D trigger							
Bit #	7	6	5	4	3	2	1	0
BASE + 00H	X	X	X	X	X	X	X	X

C.5 A/D Range Control — BASE+01H

Each A/D channel has its own individual input range, controlled by a range code stored in onboard RAM. If you want to change the range code for a given channel, select the channel as the start channel in register BASE+02H, MUX scan (described in the next section), then write the range code to bits 0 to 3 of BASE+01H.

Table C.6: Register for A/D Range Control

Write	A/D range control							
Bit #	7	6	5	4	3	2	1	0
BASE + 01H	X	X	X	X	G3*	G2*	G1	G0

G3 ~ G0 A/D range control

G0 The least significant bit (LSB) of the A/D range

G3 The most significant bit (MSB)

Range codes appear below:

PCI-1718HDU					
Input Range (V)	Unipolar/Bipolar	Gain Code			
		G3	G2	G1	G0
-5 to +5	B	0	0	0	0
-2.5 to +2.5	B	0	0	0	1
-1.25 to +1.25	B	0	0	1	0
-0.625 to +0.625	B	0	0	1	1
0 to 10V	U	0	1	0	0
0 to 5V	U	0	1	0	1
0 to 2.5V	U	0	1	1	0
0 to 1.25V	U	0	1	1	1
-10V to +10V	B	1	0	0	0
N/A		1	0	0	1
N/A		1	0	1	0
N/A		1	0	1	1
N/A		1	1	0	0
N/A		1	1	0	1
N/A		1	1	1	0
N/A		1	1	1	1

PCI-1718HGU					
Input Range (V)	Unipolar/Bipolar	Gain Code			
		G3	G2	G1	G0
±5V	B	0	0	0	0
±0.5V	B	0	0	0	1
±0.05V	B	0	0	1	0
±0.005V	B	0	0	1	1
0 to 10V	U	0	1	0	0
0 to 1V	U	0	1	0	1
0 to 0.1V	U	0	1	1	0
0 to 0.01V	U	0	1	1	1
±10V	B	1	0	0	0
±1V	B	1	0	0	1
±0.1V	B	1	0	1	0
±0.01V	B	1	0	1	1
N/A		1	1	0	0
N/A		1	1	0	1
N/A		1	1	1	0
N/A		1	1	1	1

Note: G3 and G2 are not used for PCL-818L

C.6 MUX Scan Channel Control — BASE+02H

The write register at BASE+02H controls multiplexer (MUX) scanning. The high nibble provides the stop scan channel number, and the low nibble provides the start scan channel number. Writing to this register automatically initializes the MUX to the start channel. Each A/D conversion trigger sets the MUX to the next channel.

With continuous triggering the MUX will scan from the start channel to the end channel, then repeat. For example, if the start channel is 3 and the stop channel is 7, then the scan sequence is 3, 4, 5, 6, 7, 3, 4, 5, 6, 7, 3, 4.

Table C.7: Register for MUX Scan Channel Control

Write	MUX scan channel control							
Bit #	7	6	5	4	3	2	1	0
BASE + 02H	CH3	CH2	CH1	CH0	CL3	CL2	CL1	CL0

CH3 ~ CH0 Stop scan channel number

CH0 The least significant bit (LSB) of the stop channel

CH3 The most significant bit (MSB)

CL3 ~ CL0 Start scan channel number

CL0 The least significant bit (LSB) of the start channel

CL3 The most significant bit (MSB)

The MUX scan register low nibble, CL3 to CL0, also acts as a pointer when you program the A/D input range (see previous section). When you set the MUX start channel to N, the range code written to the register BASE+01H is for channel N.

Programming example for PCI-1718HDU

This BASIC code fragment sets the range for channel 5 to ± 0.625 V:

```
200 OUT BASE+2, 5 'SET POINTER TO CH.5
```

```
210 OUT BASE+1, 3 'RANGE CODE=3 FOR  $\pm 0.625$  V
```

Note: *The MUX start/stop channel changes each time you change the input range. Do not forget to reset the MUX start and stop channels to the correct values after you finish setting the range.*

C.7 MUX Scan Channel Status — BASE+02H

Read register BASE+02H to get the current multiplexer (MUX) channel.

Table C.8: Register for MUX Scan Channel Status

Read	MUX scan channel status							
Bit #	7	6	5	4	3	2	1	0
BASE + 02H					CC3	CC2	CC1	CC0

CC3 ~ CC0 Current channel number

CC0 The least significant bit (LSB) of the stop channel

CC3 The most significant bit (MSB)

C.8 Digital I/O Registers - BASE + 03/0BH

The PCI-1718HDU/HGU provides 16 digital input channels and 16 digital output channels. You read digital input data from registers BASE+03H and BASE+0BH. After the read operation the input lines go to three-state (data is not latched).

You write digital output data to registers BASE+03H and BASE+0BH. The registers latch the output value (you cannot read it back).

Using the PCL-818HD/HD/L's input and output functions is fairly straightforward. Chapter 3 gives some ideas for digital signal connections.

Table C.9: Register for Digital Output

Write	Digital Output							
Bit #	7	6	5	4	3	2	1	0
BASE + 03H	DO7	DO6	DO5	DO4	DO3	DO2	DO1	DO0
BASE + 0BH	DO15	DO14	DO13	DO12	DO11	DO10	DO9	DO8

DO15 ~ DO0 Digital output data

DO0 The least significant bit (LSB) of the DO data

DO15 The most significant bit (MSB)

Table C.10: Register for Digital Output

Read	Digital Input							
Bit #	7	6	5	4	3	2	1	0
BASE + 03H	DI7	DI6	DI5	DI4	DI3	DI2	DI1	DI0
BASE + 0BH	DI15	DI14	DI13	DI12	DI11	DI10	DI9	DI8

DI15 ~ DI0 Digital input data

DI0 The least significant bit (LSB) of the DI data

DI15 The most significant bit (MSB)

Note: Digital Outputs D0 - D3 is selectable from the 20-pin connector or the 37-pin D connector. Please refer to chapter 2 for details.

C.9 D/A Output — BASE+04/05H

Write-only registers BASE+04H and BASE+05H accept data for D/A output.

The PCI-1718 cards provide one D/A output channel with two double-buffered 12-bit multiplying D/A converters. Write registers at addresses BASE+04H and BASE+05H hold output data. DA0 is the least significant bit (LSB) and DA11 is the most significant bit (MSB) of the D/A data.

Table C.11: Register for D/A Output

Write	D/A output data							
Bit #	7	6	5	4	3	2	1	0
BASE + 04H	DA3	DA2	DA1	DA0	X	X	X	X
BASE + 05H	DA11	DA10	DA9	DA8	DA7	DA6	DA5	DA4

DA11 ~ DA0	Analog to digital data
DA0	The least significant bit (LSB) of the D/A data
DA11	The most significant bit (MSB)

When you write data to D/A channels, write the low byte first. The low byte is temporarily held by a register in the D/A and not released to the output. After you write the high byte, the low byte and high byte are added and passed to the D/A converter. This double buffering process protects the D/A data integrity through a single step update.

The PCI-1718 cards provide a precision fixed internal -5 V or -10 V reference, selectable by means of Jumper JP10. This reference voltage is available at connector CN3 pin 11. If you use this voltage as the D/A reference input, the D/A output range is either 0 to +5 V or 0 to +10 V. You can also use an external DC or AC source as the D/A reference input. In this case, the maximum reference input voltage is ± 10 V, and the maximum D/A output ranges are 0 to +10 V or 0 to -10 V.

Connector CN3 supports all D/A signal connections. Chapter 3 gives connector pin assignments and a wiring diagram for D/A signal connections.

C.10 FIFO Interrupt Control — BASE+06H

Table C.12: Register for FIFO Interrupt Control

Write	FIFO interrupt control							
Bit #	7	6	5	4	3	2	1	0
BASE + 06H	AD12_16	X	X	X	X	X	X	FINT

FINT	Enable/disable FIFO interrupt
0	FIFO interrupt disabled
1	FIFO interrupt enabled

C.11 Clear Interrupt Request — BASE+08H

Write any value to register BASE+08H to clear the interrupt request.

Table C.13: Register for Clear Interrupt Request								
Write	A/D control							
Bit #	7	6	5	4	3	2	1	0
BASE + 09H	X	X	X	X	X	X	X	X

C.12 A/D Status — BASE+08H

Read-only register BASE+08H provides information on the A/D configuration and operation. Including:

- Bipolar or unipolar input for the channel to be converted next
- Single-ended or differential input
- Interrupt status for the channel already converted
- End of conversion for the channel already converted
- Channel to be converted next

Writing to this I/O port with any data value clears its INT bit. The other data bits do not change.

Table C.14: Register for A/D Status								
Read	A/D status							
Bit #	7	6	5	4	3	2	1	0
BASE + 08H	EOC	U/B	MUX	INT	CN3	CN2	CN1	CN0

EOC End of Conversion

- 0 The A/D conversion is idle, ready for the next conversion. Data from the previous conversion is available in the A/D data registers.
- 1 The A/D converter is busy, implying that the A/D conversion is in progress.

U/B Unipolar/bipolar mode indicator

0 Bipolar mode

1 Unipolar mode

MUX Single-ended/differential channel indicator

0 8 differential channels

1 16 single-ended channels

INT Data valid

0 No A/D conversion has been completed since the last time the INT bit was cleared. Values in the A/D data registers are not valid data.

1 The A/D conversion has finished, and converted data is ready. If the INTE bit of the control register (BASE +09H) is set, an interrupt signal will be sent to the PC bus through interrupt level IRQ_n, where n is specified by bits I2, I1 and I0 of the control register. Though the A/D status register is read-only, writing to it with any value will clear the INT bit.

 CN3 to CN0 When EOC = 0, these status bits contain the channel number of the next channel to be converted.

Note:

If you trigger the A/D conversion with the on-board pacer or an external pulse, your software should check the INT bit, not the EOC bit, before it reads the conversion data.

EOC can equal 0 in two different situations: the conversion has completed or no conversion has been started. Your software should therefore wait for the signal SNT = 1 before it reads the conversion data. It should then clear the INT bit by writing any value to the A/D status register BASE+08H.

C.13 A/D Control — BASE+09H

Read/write register BASE+09H provides information on the PCI-1718HDU/HGU's operating modes.

Table C.15: Register for A/D Control

Read/Write	A/D control							
Bit #	7	6	5	4	3	2	1	0
BASE + 09H	INTE						ST1	ST0

INTE Disable/enable generated interrupts

0 Disables the generation of interrupts. No interrupt signal can be sent to the PC bus.

1 Enables the generation of interrupts. If DMAE = 0 the PCI-1718 card will generate an interrupt when it completes an A/D conversion. Use this setting for interrupt driven data transfer.

If DMAE = 1 the PCI-1718HDU/HGU will generate an interrupt when it receives a T/C (terminal count) signal from the PC's DMA controller, indicating that a DMA transfer has completed.

Use this setting for DMA data transfer. The DMA transfer is stopped by the interrupt caused by the T/C signal. See DMAE below.

ST1 to ST0 Trigger source

Trigger source	ST1	ST0
Software trigger	0	X
External trigger	1	0
Pacer trigger	1	1

C.14 Timer/Counter Enable — BASE+0AH

Write register BASE+0AH enables or disables the PCI-1718 card's timer/counter.

Table C.16: Register for Timer/Counter Enable

Write	Timer/Counter enable							
Bit #	7	6	5	4	3	2	1	0
BASE + 0AH							TC1	TC0

TC0 Disable/enable pacer

0 Pacer enabled

1 Pacer controlled by TRIG0. This blocks trigger pulses sent from the pacer to the A/D until TRIG0 is taken high.

TC1 Counter 0 input source mode

0 Sets Counter 0 to accept external clock pulses

1 Connects Counter 0 internally to a 100 KHz clock source

C.15 Programmable Timer/Counter — BASE+0C~0FH

The four registers located at addresses BASE+0CH, BASE+0DH, BASE+0EH and BASE+0FH are used for the Intel 8254 programmable timer/counter. Please refer to the 8254 product literature for detailed application information.

C.16 Clear FIFO Interrupt Request — BASE+14H

Write any value to this I/O port to clear the FIFO's interrupt request.

Table C.17: Register for Clear FIFO Interrupt Request

Write	Clear FIFO Interrupt Request							
Bit #	7	6	5	4	3	2	1	0
BASE + 14H	X	X	X	X	X	X	X	X

C.17 A/D Data and Channel from FIFO - BASE + 17/18H

The PCL-818HD/HG stores data from A/D conversions in a 1 K word First-In First-Out (FIFO) data buffer. Registers at BASE+17H and BASE+18H store the channel number and data. The register at BASE+19H clears the FIFO buffer and sets its empty flag (EF).

Table C.18: Register for A/D Data and Channel from FIFO

Read	A/D data and channels from FIFO							
Bit #	7	6	5	4	3	2	1	0
BASE + 17H	AD3	AD2	AD1	AD0	C3	C2	C1	C0
BASE + 18H	AD11	AD10	AD9	AD8	AD7	AD6	AD5	AD4

AD11 ~ AD0	Analog to digital data
AD0	The least significant bit (LSB) of the A/D data
AD11	The most significant bit (MSB)
C3 ~ C0	A/D channel number from which the data is derived
C0	The least significant bit (LSB) of the channels
C3	The most significant bit (MSB)

C.18 FIFO Status — BASE+19H

The register at BASE+19H clears the FIFO buffer and sets its empty flag (EF). The FIFO status register, address BASE+19H, has flags which you can read to determine the current state of the FIFO buffer, including full flag, half-full flag, and empty flag.

Table C.19: Register for FIFO Status

Read	FIFO status							
Bit #	7	6	5	4	3	2	1	0
BASE + 19H						FF	HF	EF

EF FIFO empty flag

1 FIFO is empty

0 FIFO is not empty

HF FIFO half-full flag

1 FIFO is half-full or more than half-full

0 FIFO is less than half-full

FF FIFO full flag

1 FIFO is full

0 FIFO is not full

C.19 FIFO Clear — BASE+19H

Writing any value to BASE+19H clears all data in the FIFO and sets the empty flag (EF) to 1.

Table C.20: Register for FIFO Clear

Write	FIFO clear							
Bit #	7	6	5	4	3	2	1	0
BASE + 19H	X	X	X	X	X	X	X	X

C.20 Register Programming Flow Chart

C.20.1 Software Trigger Mode with Polling

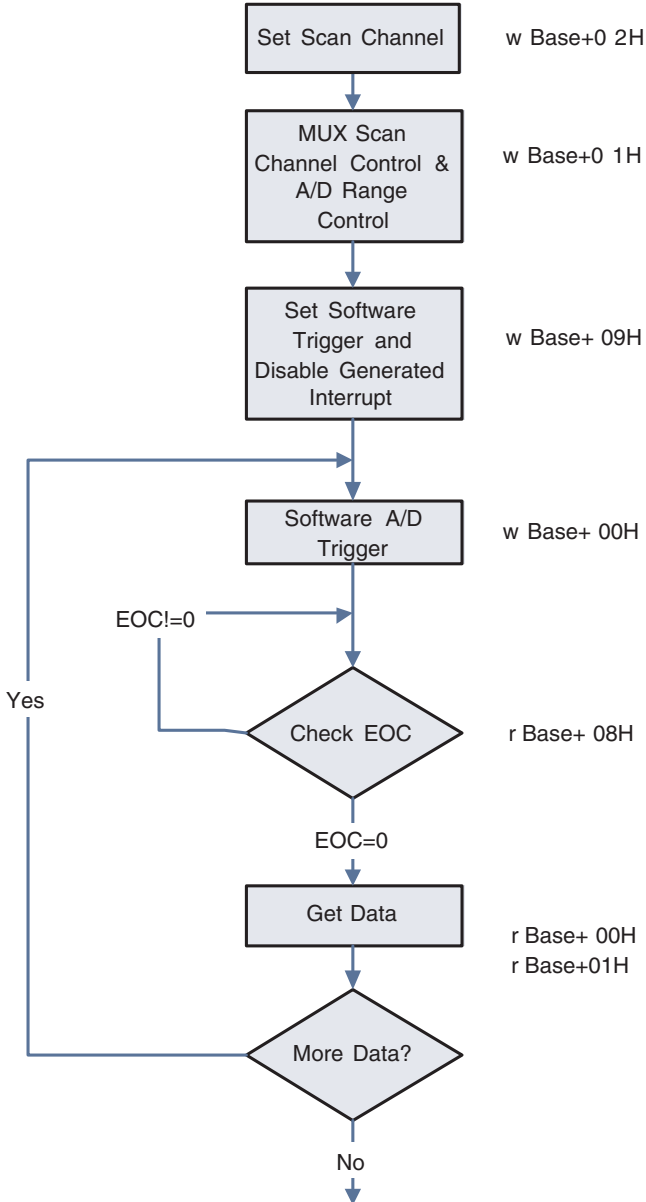

C.20.2 Pacer Trigger Mode with Interrupt

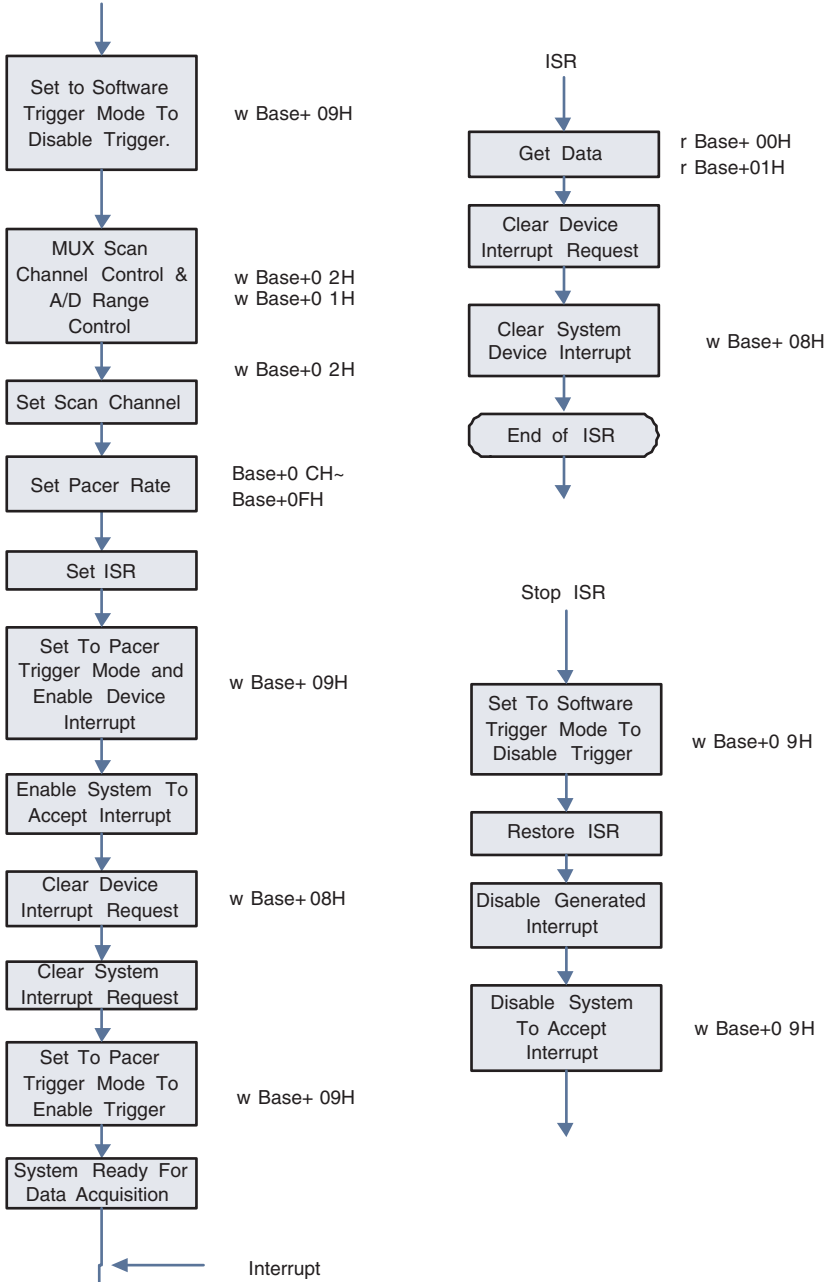

C.20.3 Pacer Trigger Mode with Interrupt [FIFO Used]

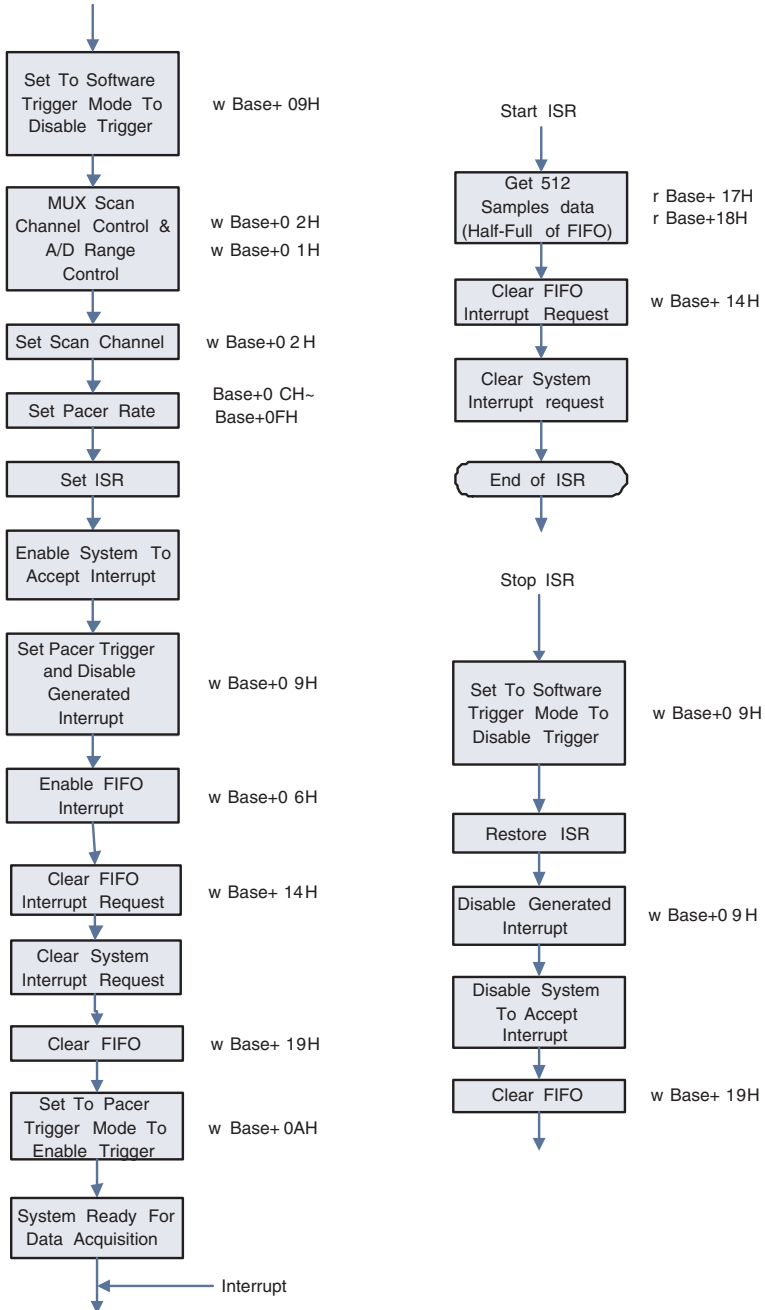

APPENDIX D

Calibration

This appendix provides brief information on PCI-1718 card calibration. Regular calibration checks are important to maintain accuracy in *data acquisition and control* applications.

Appendix D Calibration

PCI-1718 cards are calibrated at the factory for initial use. However, a recalibration of the analog input and the analog output function is recommended:

1. Every six months.
2. Everytime the analog output range is changed.

We provide a calibration program on the companion CD-ROM to assist you with D/A calibration. The calibration programs make calibration an easy job. With a variety of prompts and graphic displays, these programs will lead you through the calibration and setup procedures, showing you all the correct settings and adjustments.

Note: If you installed the program to another directory, you can find these programs in the corresponding subfolders in your destination directory.

To perform a satisfactory calibration, you will need a 4½-digit digital multi-meter and a voltage calibrator or a stable, noise-free DC voltage source.

Note: Before you calibrate the D/A function, you must turn on the power at least 15 minutes to make sure the DA&C card is already stable.

This calibration utility is designed for the Microsoft® DOS environment. Access this program from the default location:

\Program Files\Advantech\ADSAPI\Utilities\PCI-1718

D.1 VR Assignment

The six variable resistors (VRs) on the PCI-1718H DU/HGU board help you make accurate adjustment on all A/D and D/A channels. See the figure in Appendix B for help finding the VRs. The following list shows the function of each VR:

VR	Function
VR1	A/D unipolar offset
VR2	A/D full scale
VR3	A/D bipolar offset
VR4	PGA offset
VR5	D/A full scale
VR6	D/A offset

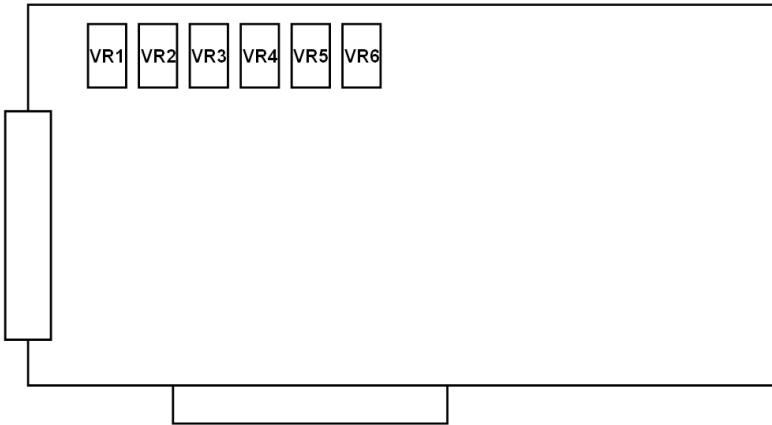

Figure D.1: PCI-1718 VR Assignment

D.2 A/D Calibration

Note: Using a precision voltmeter to calibrate the A/D outputs is recommended.

Regular and accurate calibration ensures maximum possible accuracy. The CALB.EXE calibration program leads you through the whole A/D offset and gain adjustment procedure. The basic steps are outlined below:

Short the A/D input channel 0 to ground and measure the voltage at TP1 on the PCB (see the figure in Appendix B). Adjust VR4 until TP1 is as close as possible to 0 V.

Connect a DC voltage source with value equal to 0.5 LSB (such as the D/A output) to A/D Channel 0 (pin 1 on connector CN3).

Adjust VR3 until the output from the card's A/D converter flickers between 0 and 1.

Connect a DC voltage source with a value of 4094.5 LSB (such as the D/A output) to A/D channel 0.

Adjust VR2 until the A/D reading flickers between 4094 and 4095.

Repeat steps 2 to step 5, adjusting VR2 and VR3.

Select unipolar input configuration. Connect a DC voltage source with a value of 0.5 LSB (such as the D/A output) to A/D channel 0. Adjust VR1 until the reading of the A/D flickers between 0 and 1.

D.3 D/A Calibration

Note: Using a precision voltmeter to calibrate the D/A outputs is recommended.

Connect a reference voltage within the range ± 10 V to the reference input of the D/A channel you want to calibrate. You can use either the on-board -5 V (-10 V) reference or an external reference. Adjust the full-scale gain and zero offset of the D/A channel with VR5 and VR6, respectively. Use a precision voltmeter to calibrate the D/A output.

Set the D/A data register to 0 and adjust VR6 until the output voltage equals 0 V.

Set the D/A data to 4095 and adjust VR5 until the D/A output voltage equals the reference voltage minus 1 LSB, but with the opposite sign. For example, if V_{ref} is -5 V, then V_{out} should be +4.9988 V.

